

H2 DeskPhone H2P DeskPhone

User manual



8AL90394ENAAed01

02/2020

Directory

Directory	2
1 Figures	6
2 Tables	10
3 Safety Instructio	11
4 Overview	12
4.1 Overview	12
4.2 Contents of the package	13
5 Desktop Installation.....	14
5.1 PoE and the use of external power adapters	14
5.2 Desktop and wall-mounted installation.....	15
6 Appendix Table.....	17
6.1 Appendix I - Icon	17
6.2 Appendix II - Keyboard Character Query Table.....	18
6.3 Appendix III - LED Definition.....	20
7 Introduction to the User	21
7.1 Keypad instructions.....	21
7.2 Using handset/hands-free speaker/headphone	23
7.3 Idle screen.....	23
7.4 Telephone status.....	24
7.5 Web management.....	25
7.6 Network configurations.....	26
7.7 SIP configurations.....	27
8 Basic Function.....	28
8.1 Making telephone calls.....	28
8.2 Answering calls	29
8.2.1 Communication	29
8.2.2 Make/receive second call.....	30
8.3 End of the call.....	31
8.4 Redialing	31
8.5 Auto-answering	32
8.6 Callback	32
8.7 Mute.....	33
8.7.1 Mute the call	33
8.7.2 Ringing Mute	34
8.8 Hold/resume call.....	34
8.9 DND.....	34
8.10 Call forwarding.....	36

8.11	Call transfer	37
8.11.1	Blind transfer.....	37
8.11.2	Semi-attended transfer.....	37
8.11.3	Attended transfer.....	37
8.12	Call waiting	38
8.13	Conference	39
8.13.1	Local conference.....	39
8.13.2	Network conference.....	40
8.14	Call park	41
8.15	Pick up.....	42
8.16	Anonymous call.....	43
8.16.1	Anonymous call.....	43
8.16.2	Banning anonymous calls.....	43
8.17	Hotline	44
8.18	Emergency call	45
9	Advance Function.....	46
9.1	BLF (Busy Lamp Field).....	46
9.1.1	Configure the BLF functionality	46
9.1.2	Using the BLF function	47
9.2	BLF List.....	48
9.3	Record	49
9.3.1	Recording from the server	49
9.3.2	SIP INFO recording.....	49
9.4	Agent	49
9.5	Intercom	51
9.6	MCAST	52
9.7	SCA (Shared Call Appearance).....	53
9.8	Message.....	56
9.8.1	MWI (Message Waiting Indicator)	56
10	Telephone Settings.....	57
10.1	Basic settings	57
10.1.1	Language.....	57
10.1.2	Time & date.....	57
10.1.3	Screen	59
10.1.4	Ring.....	60
10.1.5	Voice volume.....	60
10.1.6	Greeting words.....	60
10.1.7	Reboot	61
10.2	Phonebook	61
10.2.1	Local contacts.....	61
10.2.2	Blacklist.....	63

10.2.3	Cloud phonebook	64
10.3	Call Log.....	65
10.4	Function key	65
10.5	Headset.....	66
10.5.1	Wired headset	66
10.6	Advanced	67
10.6.1	Line configurations.....	67
10.6.2	Network settings	67
10.6.3	Set the Secret key	71
10.6.4	Maintenance.....	72
10.6.5	Firmware upgrade.....	74
10.6.6	Factory reset.....	76
11	Web Configurations	77
11.1	Web page authentication.....	77
11.2	Status >> Information	77
11.3	Status >> Account.....	77
11.4	Status >> Configurations.....	77
11.5	Status >> Upgrade.....	78
11.6	Status >> Auto Provision	78
11.7	Status >> Tools.....	78
11.8	Status >> Reboot Telephone.....	78
12	Network >> Basic	79
12.1	Network >> Service Port	79
12.2	Network >> VPN	80
12.3	Network >> Advanced	80
12.4	Line >> SIP	80
12.5	Line >> Dial Plan.....	86
12.6	Line >> Basic Settings.....	89
12.7	Telephone settings >> Features	90
12.8	Telephone settings >> Media settings	94
12.9	Telephone settings >> MCAST.....	95
12.10	Telephone settings >> Action.....	95
12.11	Telephone settings >> Time/Date.....	95
12.12	Telephone settings >> Tone	96
12.13	Telephone settings >> Advanced.....	97
12.14	Phonebook >> Contact.....	98
12.15	Phonebook >> Cloud phonebook	98
12.16	Phonebook >> Call List.....	100
12.17	Phonebook >> Web Dial	100
12.18	Phonebook >> Advanced.....	100

12.19	Call Log.....	101
12.20	Function Key >> Function Key	101
12.21	Function Key >> Softkey.....	102
12.22	Function Key >> Advanced	102
12.23	Application >> Manage Recording	103
12.24	Security >> Web Filter	104
12.25	Security >> Trust Certificates.....	105
12.26	Security >> Device Certificates	105
12.27	Security >> Firewall.....	106
12.28	Device Log >> Device Log.....	107
13	Troubleshooting	108
13.1	Get device system information.....	108
13.2	Reboot device	108
13.3	Reset device to factory default.....	108
13.4	Screenshot.....	108
13.5	Network packets capture.....	109
13.6	Getting log information.....	109
13.7	Common problems	110

1 Figures

Figure 1 - Desktop installation.....	15
Figure 2 - Wall-mounted installation.....	15
Figure 3 - Connecting to the device.....	16
Figure 4 - Keypad instructions.....	21
Figure 5 - Screen layout/default home screen.....	23
Figure 6 - Scroll icon.....	24
Figure 7 - Telephone status.....	24
Figure 8 - WEB phone status.....	25
Figure 9 - Login web page.....	25
Figure 10 - Telephone line SIP address and account information	27
Figure 11 - SIP registration in web	27
Figure 12 - Default line.....	28
Figure 13 - Enable voice channel dialing.....	28
Figure 14 - Open the voice channel and dial the number	28
Figure 15 - Call number	29
Figure 16 - Answering calls.....	29
Figure 17 - Communication interface.....	29
Figure 18 - The second call interface	30
Figure 19 - Two way calling.....	30
Figure 20 - Redial set	31
Figure 21 - Auto-answering enabled on the line	32
Figure 22 - Enable auto-answering in web page.....	32
Figure 23 - Set the Callback key on the telephone.....	32
Figure 24 - Set the callback key on the web page.....	33
Figure 25 - Mute the call	33
Figure 26 - Ringing mute.....	34
Figure 27 - Call hold interface.....	34
Figure 28 - Enable DND.....	34
Figure 29 - DND setting interface.....	35
Figure 30 - DND timer.....	35
Figure 31 - DND settings.....	35
Figure 32 - Line DND.....	35
Figure 33 - Set call forwarding.....	36
Figure 34 - Transfer interface	37
Figure 35 - Semi-attended transfer	37
Figure 36 - Attended transfer	37
Figure 37 - Web call waiting setting.....	38
Figure 38 - Web call waiting tone setting.....	38

Figure 39 - Local conference setting	39
Figure 40 - Local conference (1).....	39
Figure 41 - Local conference (2).....	39
Figure 42 - Network conference.....	40
Figure 43 - Setting Call Park in telephone.....	41
Figure 44 - Setting Call Park in web	41
Figure 45 - Setting Pick Up on the telephone.....	42
Figure 46 - Setting Pick Up on the web	42
Figure 47 - Enabling an anonymous web page call.....	43
Figure 48 - Anonymous call log.....	43
Figure 49 - Anonymous calls are not allowed on the telephone.....	43
Figure 50 - Page settings for blocking anonymous calls.....	44
Figure 51 - Telephone hotline setting interface.....	44
Figure 52 - Hotline set up on web page.....	44
Figure 53 - Setting up an emergency call number	45
Figure 54 - Dial the emergency number	45
Figure 55 - Web page configuration of BLF function key	46
Figure 56 - Telephone configuration of BLF function key	46
Figure 57 - Configuring the BLF List functionality.....	48
Figure 58 - BLF List number display	48
Figure 59 - Web server recording.....	49
Figure 60 - Web SIP info recording.....	49
Figure 61 - Configuring the Agent account in Normal mode	50
Figure 62 - Configuring the proxy account - Hotel Guest mode	50
Figure 63 - Agent logon page	50
Figure 64 - Figure 64 - Configuring the intercom on the Web	51
Figure 65 - Configuring the Intercom key on the web	51
Figure 66 - Setting the Multicast function key	52
Figure 67 - Multicast settings page.....	52
Figure 68 - Registering a BroadSoft account.....	53
Figure 69 - Setting the BroadSoft server	54
Figure 70 - Enabling SCA.....	54
Figure 71 - Setting the Private Hold function key	55
Figure 72 - New voice message notification	56
Figure 73 - Voice message interface.....	56
Figure 74 - Configuring the voicemail number.....	56
Figure 75 - Setting the telephone language.....	57
Figure 76 - Setting the language on the web page.....	57
Figure 77 - Setting time & date on the web page	58
Figure 78 - Setting screen parameters on the telephone.....	59
Figure 79 - Screen settings on the web.....	59

Figure 80 - Telephone screen saver.....	60
Figure 81 - Setting the telephone ring.....	60
Figure 82 - Setting the voice volume.....	60
Figure 83 - Phonebook screen.....	61
Figure 84 - Local phonebook.....	61
Figure 85 - Adding a new contact.....	62
Figure 86 - Group list.....	62
Figure 87 - Browsing contacts in a group.....	62
Figure 88 - Adding contacts to a group.....	62
Figure 89 - Adding to the blacklist.....	63
Figure 90 - Blacklist on the web page.....	63
Figure 91 - Cloud phonebook list.....	64
Figure 92 - Downloading the cloud phonebook.....	64
Figure 93 - Browsing contacts in the cloud phonebook.....	64
Figure 94 - Call Log.....	65
Figure 95 - Filtering call record types.....	65
Figure 96 - DSS key configuration screen.....	65
Figure 97 - DSS key settings.....	66
Figure 98 - Headset function settings.....	67
Figure 99 - SIP address and account information.....	67
Figure 100 - Configuring advanced line options.....	67
Figure 101 - Network mode settings.....	67
Figure 102 - DHCP network mode.....	68
Figure 103 - PPPoE network mode.....	68
Figure 104 - Static IP network mode.....	68
Figure 105 - IPv6 static IP network mode.....	68
Figure 106 - Configuring the web server type.....	70
Figure 107 - Setting the admin password in the web.....	71
Figure 108 - Keyboard lock settings on the web.....	71
Figure 109 - Auto provision settings.....	72
Figure 110 - Web page firmware upgrade.....	74
Figure 111 - Firmware upgrade.....	75
Figure 112 - Service port settings.....	79
Figure 113 - Dial plan settings.....	86
Figure 114 - Custom setting of dial-up rules.....	87
Figure 115 - Dial rules table (1).....	88
Figure 116 - Dialing rules table (2).....	88
Figure 117 - Dialing rules table (3).....	89
Figure 118 - Dialing rules table (4).....	89
Figure 119 - Tone settings on the web.....	97
Figure 120 - Managing cloud phonebooks.....	98

Figure 121 - LDAP setting.....	99
Figure 122 - Cloud phonebook browsing	100
Figure 123 - Global key settings	103
Figure 124 - Programmable key settings	103
Figure 125 - Web filter settings	104
Figure 126 - Web Filter Table	104
Figure 127 - Certificate of settings	105
Figure 128 - Device certificate setting	105
Figure 129 - Network firewall settings.....	106
Figure 130 - Firewall input rule table.....	107
Figure 131 - Delete firewall rules.....	107
Figure 132 - Screenshot	108
Figure 133 - Web capture	109

2 Tables

Table 1 - Hardware Interface Description.....	16
Table 2 - Keypad Icons.....	17
Table 3 - Status Prompt and Notification Icons.....	17
Table 4 - Look-up Table of Characters	18
Table 5 - LED Status.....	20
Table 6 - Keypad instructions.....	22
Table 7 - Communication Mode.....	30
Table 8 - BLF Function Key Subtype Parameter List.....	46
Table 9 - Agency mode.....	50
Table 10 - Intercom Configuration.....	51
Table 11 - MCAST Parameters on the Web.....	53
Table 12 - LED Status of SCA.....	55
Table 13 - Time Settings Parameters.....	58
Table 14 - QoS & VLAN.....	69
Table 15 - Auto Provision	72
Table 16 - Firmware Upgrade.....	74
Table 17 - Service Port.....	79
Table 18 - Line configuration on the web page.....	80
Table 19 - Telephone Dialing Methods	86
Table 20 - Dial-up Rule Configuration Table.....	87
Table 21 - Set the line global configuration on the web page.....	89
Table 22 - General Function Settings.....	90
Table 23 - Voice Settings.....	94
Table 24 - Multicast Parameters.....	95
Table 25 - Time&Date Settings	95
Table 26 - Function Key Configuration	101
Table 27 - Softkey Configuration	102
Table 28 - Network Firewall	106
Table 29 - Problems.....	110

3 Safety Instructio

Please read the following safety notices before installing or using this unit. They are crucial for the safe and reliable operation of the device.

- Please use the external power supply that is included in the package. Another power source may cause damage to the telephone and affect its behavior or induce noise.
- Before using the external power supply in the package, please check the home power voltage. Inaccurate power voltage may cause fire and damage.
- Please do not damage the power cord. If the power cord or plug is impaired, do not use it because it may cause fire or electric shock.
- Do not drop, knock or shake the telephone. Rough handling can break internal circuit boards.
- This telephone is designed for indoor use. Do not install the device in places where there is direct sunlight. Also do not put the device on carpets or cushions. It may cause fire or breakdown.
- Avoid exposure of the telephone to high temperatures or those below 0°C, or to high humidity.
- Avoid getting the unit wet with any liquid.
- Do not attempt to open it. Non-expert handling of the device could damage it. Consult your authorized dealer for help or else it may cause fire, electric shock or breakdown.
- Do not use harsh chemicals, cleaning solvents or strong detergents to clean it. Wipe it clean with a soft cloth that has been slightly dampened in a mild soap and water solution.
- Do not touch the power plug in the event of lightning as this may cause an electric shock.
- Do not install this telephone in a poorly ventilated place as this could cause bodily injury. Before you work on any equipment, be aware of the hazards involved with electrical circuitry and be familiar with standard practices for preventing accidents.

4 Overview

4.1 Overview

The H2/H2P is a type of telephone designed for small and medium-sized enterprises and families. H2/H2P telephones greatly improve enterprise production efficiency with advanced design, high cost performance, and paperless office operation. It is not only a desktop telephone, but also an elegant item that can be put in a sitting room or office.

The device is the latest generation of IP Phone, which supports many excellent features, such as high- definition voice, headphones and high-performance echo-cancellation full duplex speakers, fast ethernet, QoS, encryption transmission, automatic configuration, a new system, smooth operation, flat interface settings and many other advantages.

For business users, H2/H2P telephones are the cost-effective office equipment; while promoting environmental protection, they also provide convenient operation. For family users, H2/H2P telephones are a highly efficient communication device. Users can flexibly configure and define the functions of two DSS keys, saving space and cost. It is an ideal choice for both business and family users who pursue high quality and high efficiency.

In order to help some interested users better understand the details of the product, this user manual can be used as a reference guide for the use of H2/H2P telephones. This document may not be applicable to the latest version of the software. If you have any questions, you can use the telephone's help prompt interface or download and update your user manual from the official website.

4.2 Contents of the package

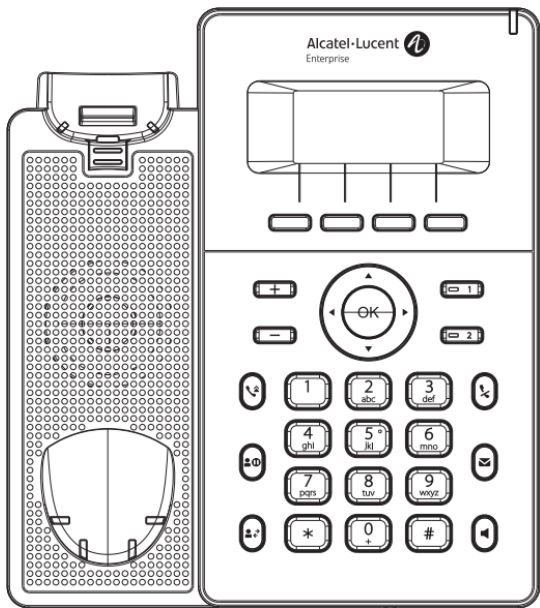

Telephone



Handset

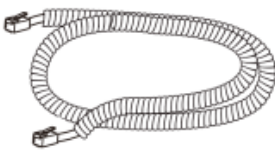

Receiver cable

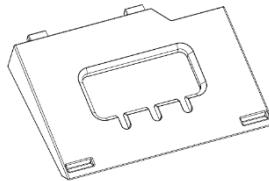

2-degree adjustable foot



Network cable

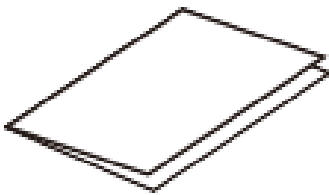

Quick Installation Guide,
Safety Sheet

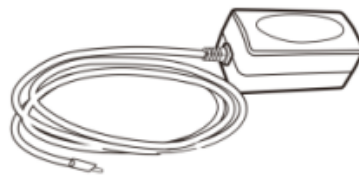

Power adapter (buy separately)

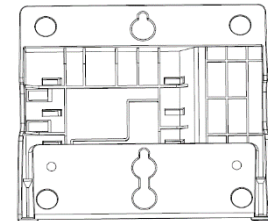

Wall stand (buy separately)

5 Desktop Installation

5.1 PoE and the use of external power adapters

H2P telephones support two power supply modes, from an external power adapter or a Power-over-Ethernet (PoE) compliant switch. The H2 telephone does not support PoE function.

The PoE power supply saves the space and cost of providing the device with an additional power outlet. With a PoE switch, the device can be powered through a single Ethernet cable which is also used for data transmission. By attaching a UPS system to the PoE switch, the device can keep working during power outages just like a traditional PSTN telephone which is powered by the telephone line.

For users who do not have PoE equipment, the traditional power adaptor should be used. If the device is connected to a PoE switch and power adapter at the same time, the power adapter will be used as the priority source, and the device will switch to the PoE power supply once the power adaptor source fails.

Use standard power adapters and a PoE switch conforming to specifications to ensure the proper operation of the equipment.

5.2 Desktop and wall-mounted installation

The device supports two installation modes, desktop and wall-mounted. If the telephone is on the desktop, please follow the instructions in the picture below to install the telephone.

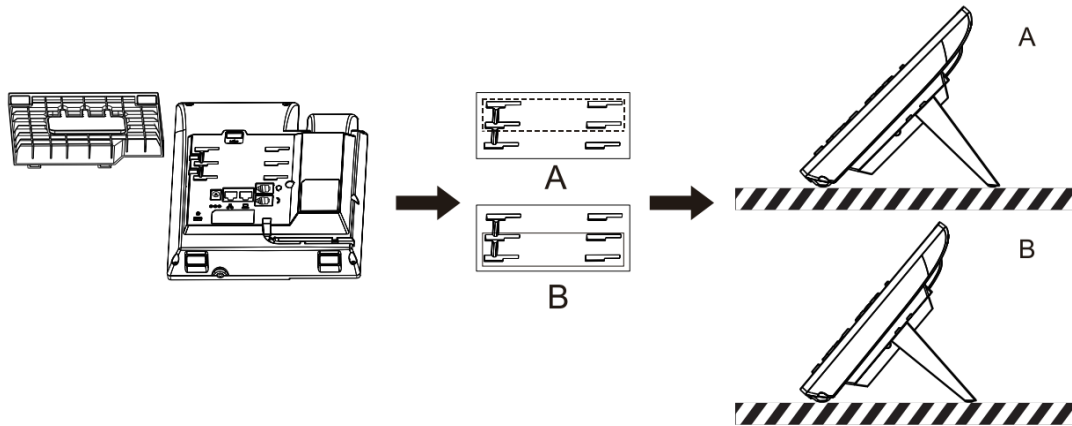

Figure 1 - Desktop installation

If the telephone is mounted on the wall, please follow the instructions below to install it.

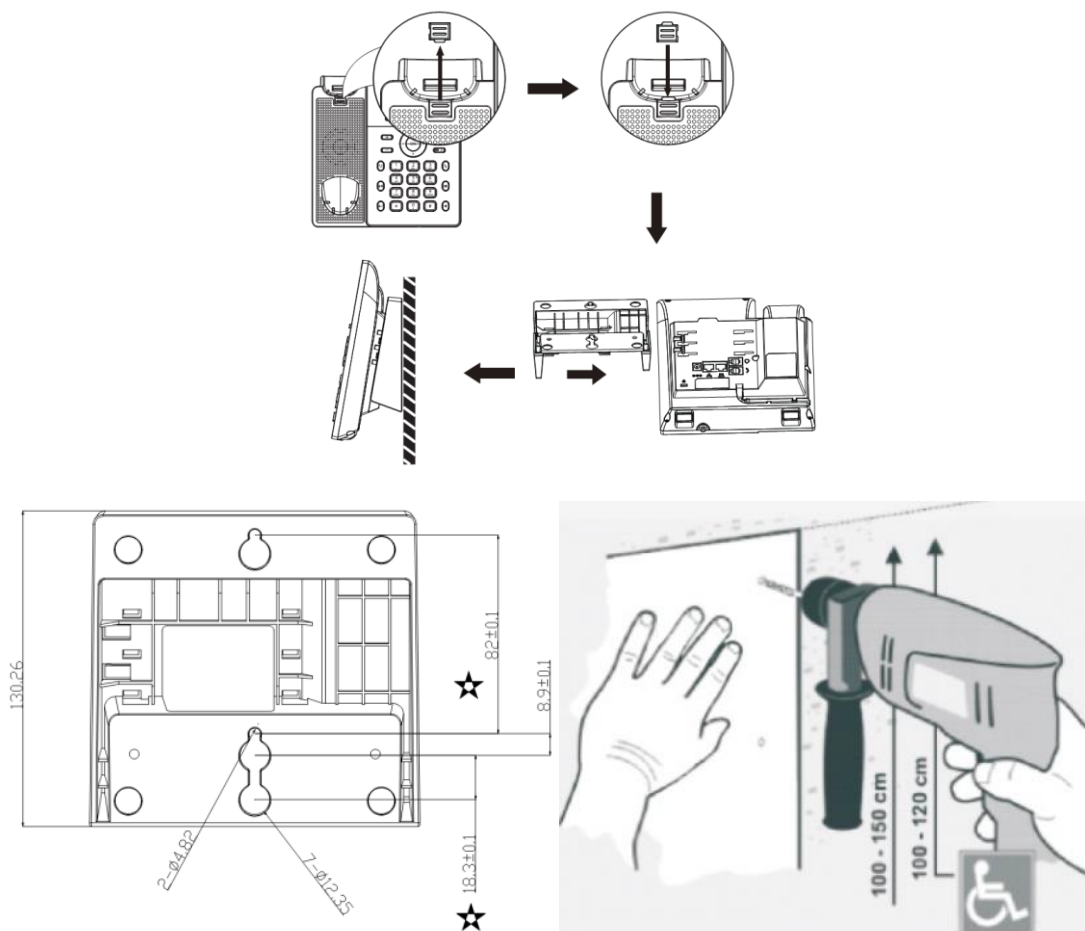

Figure 2 - Wall-mounted installation

Connect the power adapter, network, PC, telephone and earphone to the appropriate port as shown in the picture below.

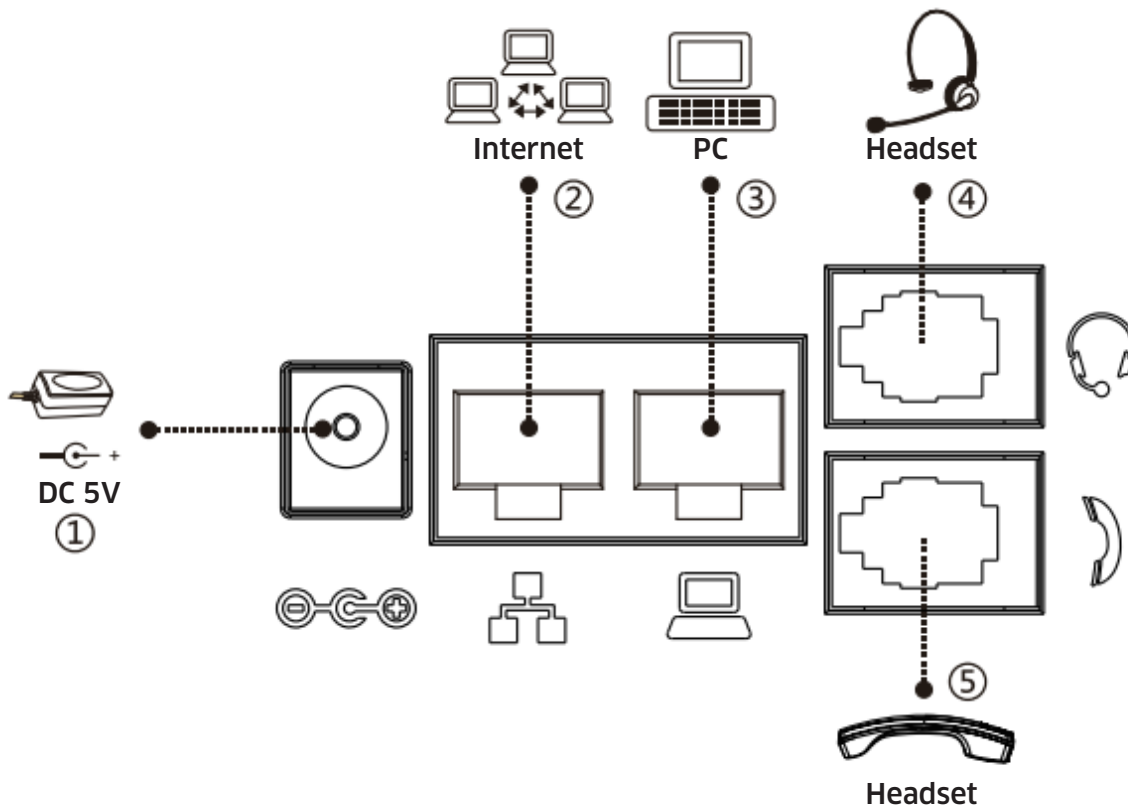

Figure 3 - Connecting to the device

Table 1 - Hardware Interface Description

Index	Interface	Description
①	Power Interface	Connecting the power adapter
②	Network Interface	Connecting to LAN or Internet
③	PC Port	Network interface for connecting the computer
④	Headset Interface	Connecting the headset
⑤	Receiver Interface	Connecting the microphone receiver

6 Appendix Table

6.1 Appendix I - Icon

Table 2 - Keypad Icons































Icon	Description
	Volume down
	Volume up
	Redial
	Call hold/resume
	Call transfer
	Mute microphone (during call)
	MWI
	Handsfree



























Table 3 - Status Prompt and Notification Icons

























H2/H2P Icon	Description
	Call out
	Call in
	Call hold
	Network connected
	Network disconnected
	No IP address
	Open VLAN or VPN
	Keypad locked
	Call forward calls
	Outgoing calls
	Incoming calls
	Missed calls
	New voice message waiting
	Do-Not-Disturb inactivated on telephone
	Call forward activated
	Auto-answering activated
	Hands-free (HF) mode
	Headphone (HP) mode
	Handset (HS) mode
	Mute microphone
	The voice quality of calling
	The voice encryption of calling

H2/H2P Icon	Description
HD	Speech High Definition
	Record

6.2 Appendix II - Keyboard Character Query Table

Table 4 - Look-up Table of Characters

Mode Icon	Text Mode	Key Button	Characters of Each Press
	Numeric		1
			2
			3
			4
			5
			6
			7
			8
			9
			0
			*
			#
	Lower Case Alphabets		
			a b c
			d e f
			g h i
			j k l
			m n o
			p q r s
			t u v
			w x y z
			
			
			

Mode Icon	Text Mode	Key Button	Characters of Each Press
	Upper Case Alphabets		
			A B C
			D E F
			G H I
			J K L
			M N O
			P Q R S
			T U V
			W X Y Z
			
			
			
			Digital/ Alphabets
	a b c A B C 2		
	d e f D E F 3		
	g h I G H I 4		
	j k l J K L 5		
	m n o M N O 6		
	p q r s P Q R S 7		
	t u v T U V 8		
	w x y z W X Y Z 9		
	+ . , ; : \ ? ! 0		
	% \$ / ~ & () [] = *		
	@ #		

6.3 Appendix III - LED Definition

Table 5 - LED Status

Type	LED Light	Status
Line Key LED	Off	Line inactive
	Blue on	Line ready (registered)
	Blue blinking	Ringing
	Red blinking	Line is trying to register
	Red blinking	Line error (registration failure)
	Red on	Dialing/line in use (talking)
	Light red blinking	Call holding
BLF	Blue on	Subscription number is idle.
	Red on	Subscription number is busy.
	Red on	Subscription number is dialing.
	Off	Subscription number is unavailable.
Presence	Blue on	Subscription number is idle.
	Red on	Subscription number is busy.
	Red on	Subscription number is dialing.
	Off	Subscription number is unavailable.
DND	Red on	Enable DND
	Off	Disable DND
MWI	Blue blinking	New voice message waiting
	Off	No new voice message
Message indicator LED	Off	Talk/dial.
	Off	Hold/held
	Off	Mute.
	Off	Common.
	Fast blink	Ringing.
	Slow blink	Missed call.
	Slow blink	Voice mail.

Note: H2/H2P telephones have only 3 LEDs. There is a red message indicator LED at the upper right corner. In the middle, there are 2 line keys, each with a red-blue bi-color LED. A line key can be configured as another function key, such as: BLF, Presence, DND, MWI, etc. See [10.4 Function key for details](#).

7 Introduction to the User

7.1 Keypad instructions

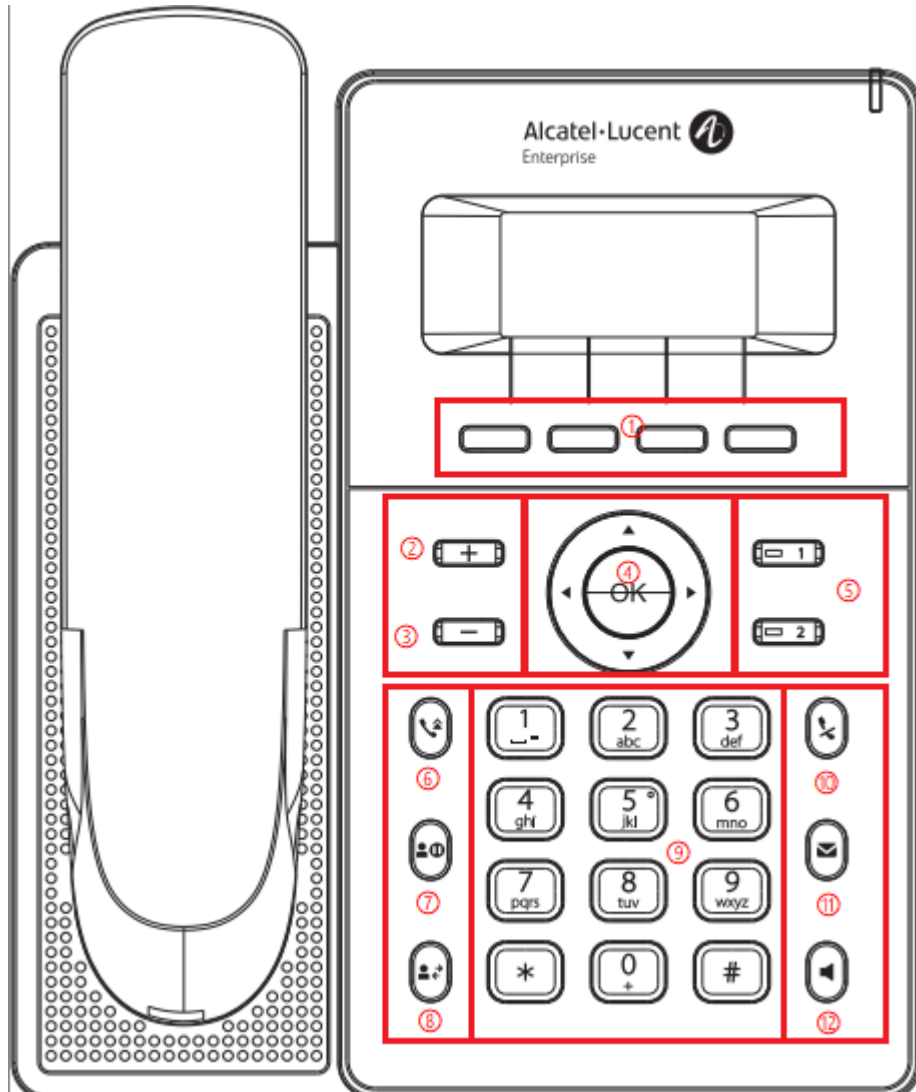

Figure 4 - Keypad instructions

The picture above shows the telephone's keypad layout. Each button has its own specific function. Users can refer to the instructions for the keys in the illustration in this section to operate the telephone.

Table 6 - Keypad instructions

Number	The keypad names	Instructions
1	Soft-menu buttons	These four buttons provide different functions corresponding to the soft-menu displayed on the screen.
2	Volume Up Key	In standby or ringing status, press this button to increase the ring volume; in talk status, press this button to increase the voice volume.
3	Volume Down Key	In standby or ringing status, press this button to decrease the ring volume; in talk status, press this button to decrease the voice volume.
4	Navigate/OK Keys	Navigate Key: The user can press the up/down navigation key to change the line or move the cursor in the screen list. On some settings and text editing pages, the user can press the left/right navigation key to change options or move the cursor in the screen list to the left/right. OK key: The default is equivalent to soft button confirmation. User can customize the function of Navigate/OK keys. For example, the up navigation key can be configured as the Call Log key, the OK key can be configured as the Status key.
5	Line key	Default is line 1/line 2; supports the custom configuration of the DSS key.
6	Transfer Key	By pressing the “Transfer” key, the user can transfer the current call to another user.
7	Hold Key	By pressing the “Hold” key during the call, the user can hold the call and then press it again to cancel the hold and restore normal call status.
8	Redial	Press the “Redial” key to redial the last number dialed.
9	Standard Telephone Keys	The 12 standard telephone keys provide the standard telephone functions. Furthermore, some keys also provide special functions by long-pressing the key, Key # - Long-pressed to lock the phone.
10	Mute Key	During a call, the user can press this key to mute the microphone.
11	MWI	Press the “voice mail” button, and the user enters the voice mail list interface.
12	Hands-free Key	The user can press this key to open the speakerphone.

7.2 Using handset/hands-free speaker/headphone

■ Using the handset

To talk over the handset, the user should lift the handset off the device and dial the number or dial the number first, then lift the handset, and the number will be dialed. The user can switch the audio channel to the handset by lifting the handset when the audio channel is turned on in the speaker or headphones.

■ Using the hands-free speaker

To talk over the hands-free speaker, the user should press the hands-free button and then dial the number, or dial the number first and then press the hands-free button. The user can switch the audio channel to the speaker from the handset by pressing the hands-free button when the audio channel is open in the handset.

■ Using the headphone

To use the headphone by default, the user should press the headset button, which is defined by the DSS key or soft key to turn on the headphone. In the same manner as the handset and hands-free speaker, the user can dial the number before or after the headphone is turned on. For the DSS key configuration, please refer to [10.4 Function key](#).

■ Using line keys (defined by DSS key)

The user can use a line key to make or answer a call on a specific line. If the handset has been lifted, the audio channel will be opened in the handset. Otherwise, the audio channel will be opened in the hands-free speaker or headphone.

7.3 Idle screen



Figure 5 - Screen layout/default home screen

The image above shows the default standby screen, which is the user interface most of the time. The upper part of the home screen shows the status of the device, information and data that can be edited (such as voice messages, missed calls, auto answer, do not disturb, lock status, network connection status, etc.).

The lower part of the screen is the function menu keys, which are the first layer of the function menu through which users can operate the telephone.

Users can restore the telephone to the default standby screen interface by picking up and dropping the handset.

The left and right part of the screen show the default configuration of Side keys, which dynamically display the configuration of the SIP information, message, headset, etc., which can be customized by users.

The icons are described in [6.1 Appendix I - Icon](#).

On some screens, there are many items or long text to be displayed which cannot fit onto the screen. These are arranged in a list or multiple lines with a scroll bar. If the user sees a scroll bar, he can use the up/down navigator buttons to scroll through the list.



Figure 6 - Scroll icon

7.4 Telephone status

The telephone status includes the following information about the telephone:

- work status: VLAN ID
IPv4 or IPv6 status
IP address
Network mode
- Version information:
Mac address
Phone mode
Hardware version number
Software version number
Phone storage (RAM and ROM)
System running time
- SIP account information:
SIP account
SIP account status (registered/unapplied/trying/time out)
- TR069 connect status

The user can view the TR069 connect status through the telephone interface.

- Telephone interface:

When the telephone is in standby mode, press [**Setting**] >> [**Network**] and select the option to view the corresponding information, as shown in the figure:

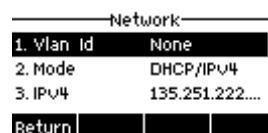

Figure 7 - Telephone status

- WEB interface:

Refer to [7.5 Web management](#) to log in to the telephone page, enter the [**Status**] >> [**Information**] page, and check the telephone status, as shown in the figure:

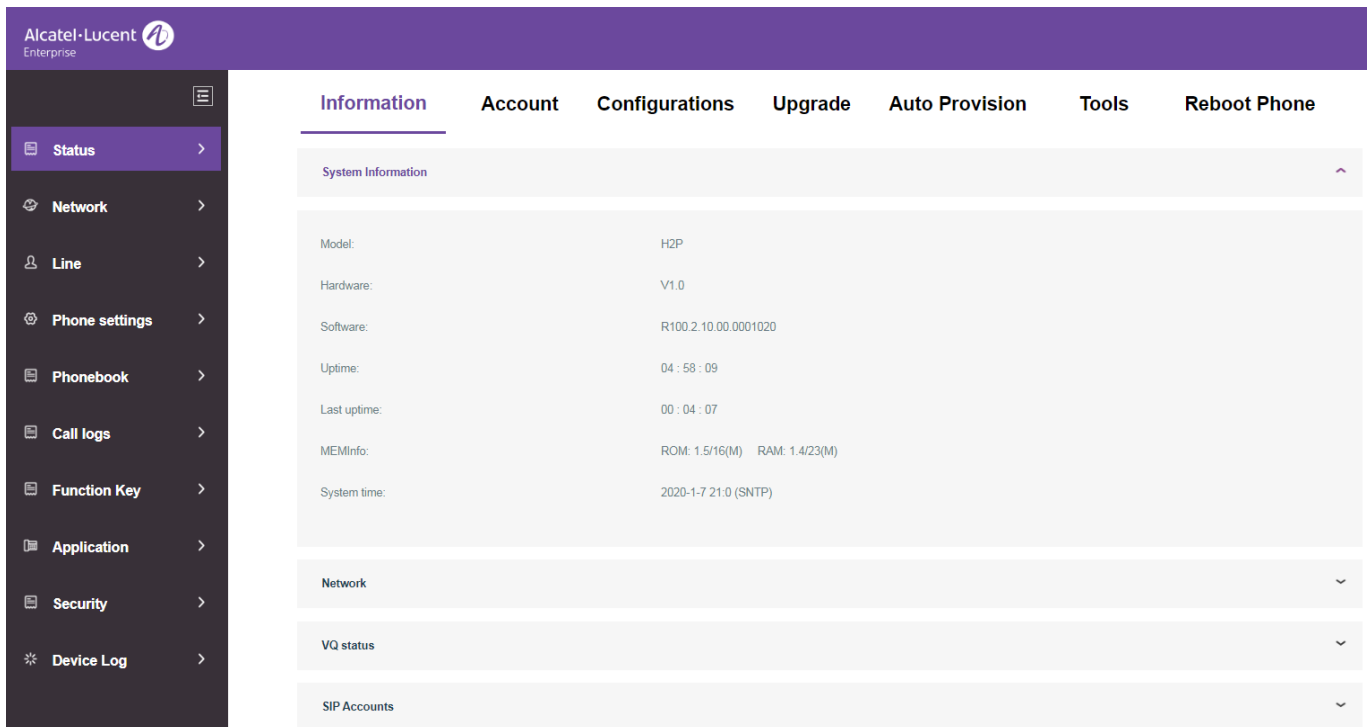

Figure 8 - WEB phone status

7.5 Web management

The telephone can be configured and managed on the telephone's web page. The user enters the IP address of the telephone in the browser and first opens the telephone's web page. The user can check the IP address of the telephone by pressing **[Setting]** >> **[Network]**.

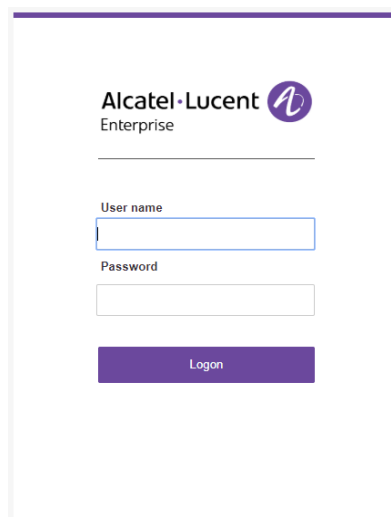

Figure 9 - Login web page

Users must correctly enter the user name and password to log in to the web page. **The default user name and password are “admin/123456”.** For details of the web page operation, please refer to [11 Web Configurations](#).

7.6 Network configurations

The device relies on an IP network connection to provide service. Unlike traditional telephone systems based on a circuit switching technology, IP devices are connected to each other over the network and exchange data on a packet basis based on the devices' IP addresses.

To enable this telephone, you must first correctly configure the network configuration. To configure the network, users need to find the telephone function menu button **[Setting]** >> **[Admin]** >> **[IP param]**. The default password for Admin interface is "123456".

NOTE: If the user sees a 'WAN Disconnected' icon  flashing in the middle of screen, it means the network cable was not correctly connected to the device's network port. Please check if the cables are connected correctly to the device, network switch, router, or modem.

The device supports three types of networks, IPv4/IPv6/IPv4&IPv6. There are three common IP configuration modes in IPv4.

- Dynamic Host Configuration Protocol (DHCP) – This is the automatic configuration mode acquired through network configurations from a DHCP server. Users don't need to configure any parameters manually. All configuration parameters will come from the DHCP server and be applied to the device. This is recommended for most users.
- Static IP – This option allows the user to configure each IP parameter manually, including the IP Address, Subnet Mask, Default Gateway, and DNS servers. This is normally used in some professional network user environments.
- PPPoE – This option is often used by users who connect the device to a broadband modem or router. To establish a PPPoE connection, the user should configure the username and password provided by the service provider.

The device is configured in DHCP mode by default. There are two common IP configuration modes in IPv6.

- DHCP – This is the automatic configuration mode acquired via network configurations from a DHCP server. Users need not configure any parameters manually. All configuration parameters come from the DHCP server and are applied to the device. This is recommended for most users.
- Static IP - This option allows users to manually configure each IP parameter, including the IP address, mask, gateway, and primary and secondary domains. This is usually applied to certain professional network user environments.

Please see [10.6.2.1 Network settings](#) for detailed configuration and use.

7.7 SIP configurations

A line must be configured properly to be able to provide telephone service. The line configuration is like a virtualized SIM card on a mobile telephone which stores the service provider and the account information used for registration and authentication. When the device is properly configured, it will register the device to the service provider with the server's address and user's authentication as stored in the configurations.

The user can configure a line on the telephone or web page interface and input the corresponding information such as the registered address, registered user name, registered password and SIP user and registered port, which are provided by the SIP server administrator.

- **Telephone interface:** To manually configure a line, the user presses the button in the function menu **[Setting]** >> **[Admin]** >> **[SIP Accounts]** to set up the configuration. Click OK to save the configuration.

NOTE: User must enter correct password to enter Admin interface in order to edit the SIP configurations (default password is 123456).

The parameters and screens are listed below.

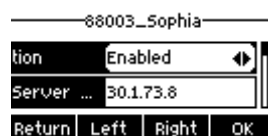

Figure 10 - Telephone line SIP address and account information

- **WEB interface:** After logging into the telephone page, enter **[Line]** >> **[SIP]** for Register Setting, and click Apply to complete the registration after configuration, as shown below:

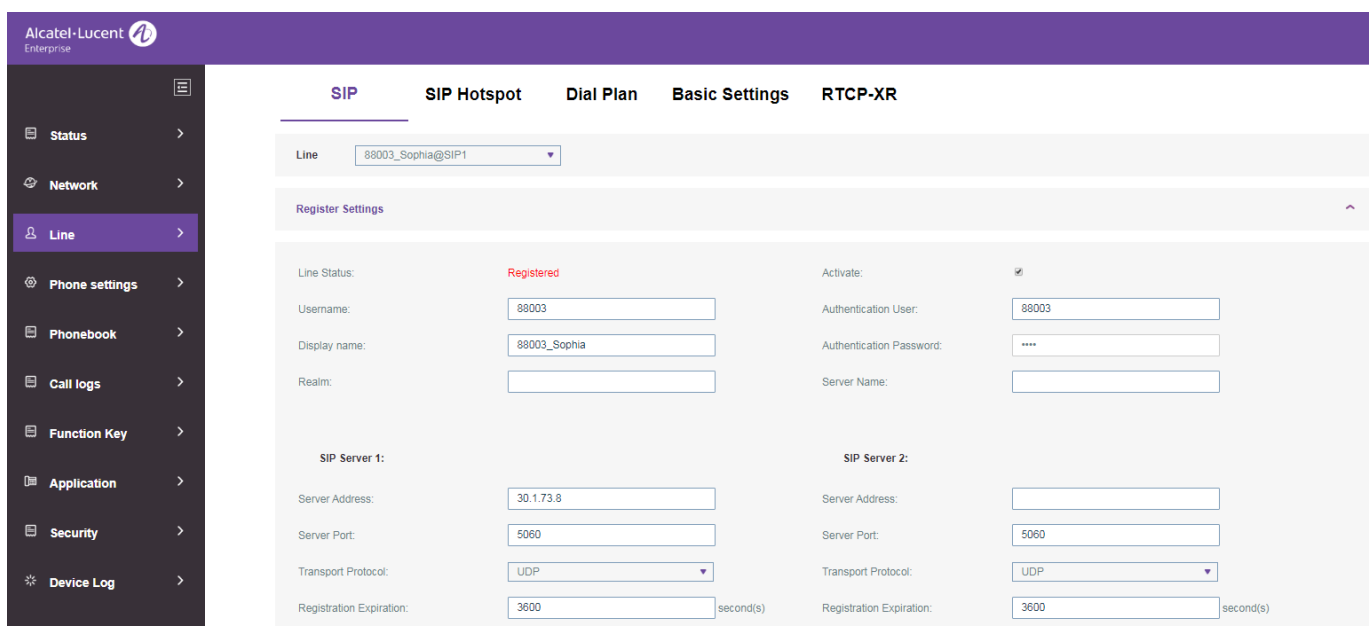

Figure 11 - SIP registration in web

8 Basic Function

8.1 Making telephone calls

■ Default line

The device provides two line services. If both lines are configured, the user can make or receive telephone calls on either line. If one or two lines are configured, the default line name is displayed in the top left corner. To enable or disable the default line, the user can configure it in the web interface (Telephone settings/Features/Basic Settings).



Figure 12 - Default line

■ Dialing methods

The user can dial a number by

- Entering the number directly
- Selecting a telephone number from phonebook contacts (Refer to [10.2.1 Local contacts](#))
- Selecting a telephone number from cloud phonebook contacts (Refer to [10.2.3 Cloud phonebook](#))
- Selecting a telephone number from call logs (Refer to [10.3 Call Log](#))
- Redialing the last dialed number

■ Dial number, then open audio channel

To make a telephone call, the user first dials a number by one of the above methods. When the dialed number is completed, the user can press the **[Dial]** button on the soft-menu, or press the hand-free button to turn on the speaker, or press the  soft key to turn on the headphone, or lift the handset to call out with the current line, or press the line key to call out with a specified line.



Figure 13 - Enable voice channel dialing

■ Open audio channel then dial the number

Another alternative is the traditional way in which the user first opens the audio channel by lifting the handset, or by pressing the hands-free button, or pressing the line key, and then dialing the number. When completing the number, the user can press the **[Dial]** button or the **[OK]** button to call out. The number can also be dialed out automatically after a timeout.



Figure 14 - Open the voice channel and dial the number

■ Cancelling a call

While calling the number, the user can stop the audio channel by putting back the handset, pressing the hands-free button or pressing the **[End]** button to drop the call.



Figure 15 - Call number

8.2 Answering calls

When there is an incoming call, the user will see the following incoming call on the screen.



Figure 16 - Answering calls

The user can answer the Call by lifting the handset, pressing the hands-free button, or pressing the **[Answer]** button. To reject the incoming call, the user should press the **[More]** and then the **[Reject]** button.

8.2.1 Communication

When the call is connected, the user will see a communication mode screen as in the figure below.



Figure 17 - Communication interface

Table 7 - Communication Mode

Number	Name	Description
①	Voice channel	The icon shows the voice channel mode being used.
②	Default line	The line currently used by the telephone.
③	Calls to end	The name or number of the person on the other end of the call.
④	Call duration	The duration of a call after it has been established.
⑤	Number of lines	Shows how many calls are present on the current device.
⑥	Speech quality	Displays the current voice quality of the call.
⑦	HD voice	Displays the HD logo when G.722 codec is used in a call

8.2.2 Make/receive second call

The device can support up to two concurrent calls. When there is already a call established, the user can still answer another incoming call on either line or make a second call on either line.

■ Second incoming call

When there is another incoming call during a telephone call, this call will be waiting for the user to answer. The user will see the call message in the middle of the current screen. The device will not be ringing, but will be playing the call waiting tone in the audio channel of the current call, and the LED will be flashing blue.

The user can accept or reject the call the same as for normal incoming calls. When the waiting call is answered, the first call will be automatically put on hold.



Figure 18 - The second call interface

■ Second outgoing call

To make a second call, the user may press the [Xfer]/[Conf] button to make a new call on the default line or press the line key to make new call on a specific line. Then dial the number the same way as when making a telephone call. An alternative for making a second call is to press the DSS key which was configured as BLF or Speed Dial. When the user is making a second call with the above methods, the first call could be put on hold manually, or it will be put on hold automatically with the second dial.

■ Switching between two calls

When there are two calls established, the user will see a dual call screen as illustrated below..



Figure 19 - Two way calling

The user can press the up/down navigator buttons to switch the screen page and switch the call

focus by pressing the **[Resume]** button.

■ Ending one call

The user may hang up the current call by pressing the **[More]** and then the **[End]** button. The device will return to single call mode in hold status. The user can then press the **[Resume]** button to resume the call.

8.3 End of the call

After the user finishes talking, the user can put the handset back on the telephone, and then press the hands-free button or soft key **[End]** to close the voice channel and end the call.

Note: When the telephone is in “Hold” status, the user must press the [Resume] key to return to communication status, and then put the handset back or press the hands-free button to end the call.

8.4 Redialing

- Redialing the last outgoing number:
When the telephone is in standby mode, press the redial button and the telephone will call out the last outgoing number.
- Call out any number with the redial key:
Enter the number, press the redial key, and the telephone will call out the number on the dial.
- Press the redial key to enter the call record:
Log in to the telephone page, enter **[Phone Settings]** >> **[Features]** >> **[Redial Settings]**, check **Redial Enter Call Log**. Press the redial button when in standby to enter the Call Log page, and press again to call out using the current located number.

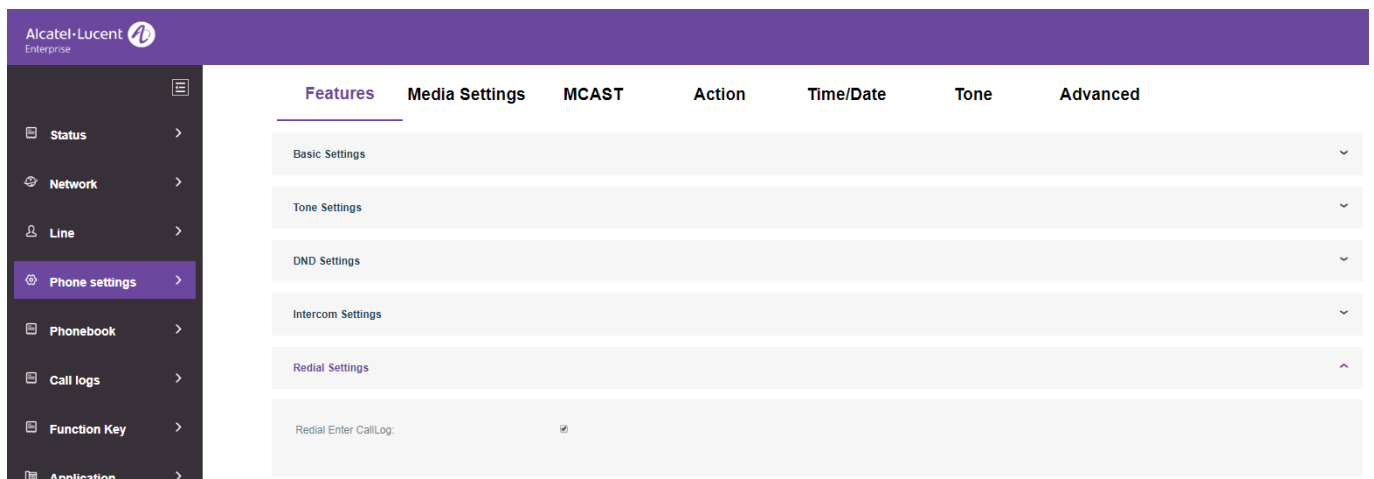

Figure 20 - Redial set

8.5 Auto-answering

The user may turn on auto-answering mode on the device, and any incoming call will be automatically answered. Auto-answering can be enabled on a line basis. The user can start the automatic answering function in the webpage interface.

The icon in the upper right corner of the screen  indicates that auto answering is enabled.



Figure 21 - Auto-answering enabled on the line

- **WEB interface:**

Log in to the telephone page, enter [Line] >> [SIP], select [Basic settings], check **Enable Auto Answering**, and click Apply after setting the **Auto Answering Delay** time.

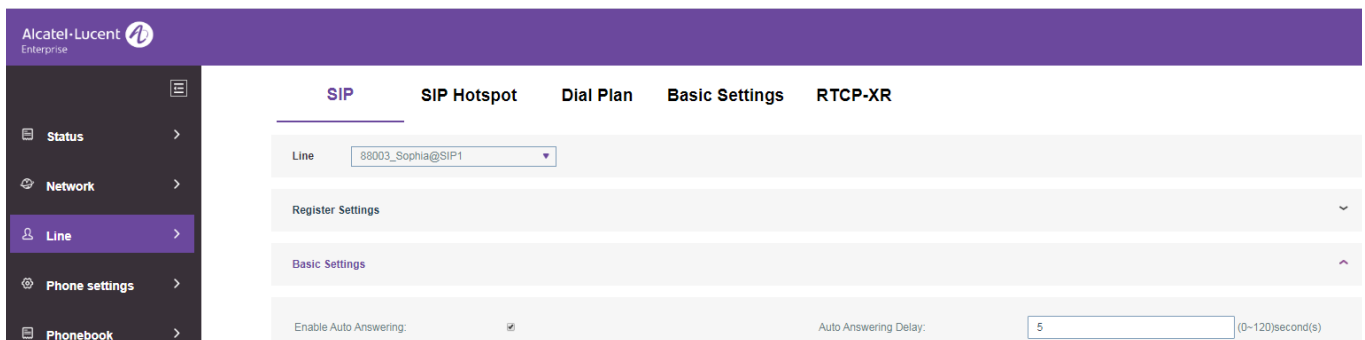

Figure 22 - Enable auto-answering in web page

8.6 Callback

The user can dial the number of the last missed call. If there is no call history, press the [Callback] button and the telephone will say “can’t process”.

- Set the Callback key through the telephone interface:
Under Standby, long press the line key, enter the [DSSkey] setting interface, select the Dsskey, set type to Key Event, set key to Callback function, input the callback key name, and press the [OK] key to save.

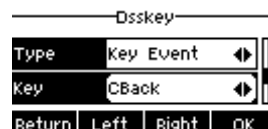

Figure 23 - Set the Callback key on the telephone

- Set the Callback key through the web interface:
Log in to the telephone page, enter the **[Function Key]** >> **[Function Key]** page, select the function key, set the type as Key Event, and set the subtype as Callback, as shown in the figure below:

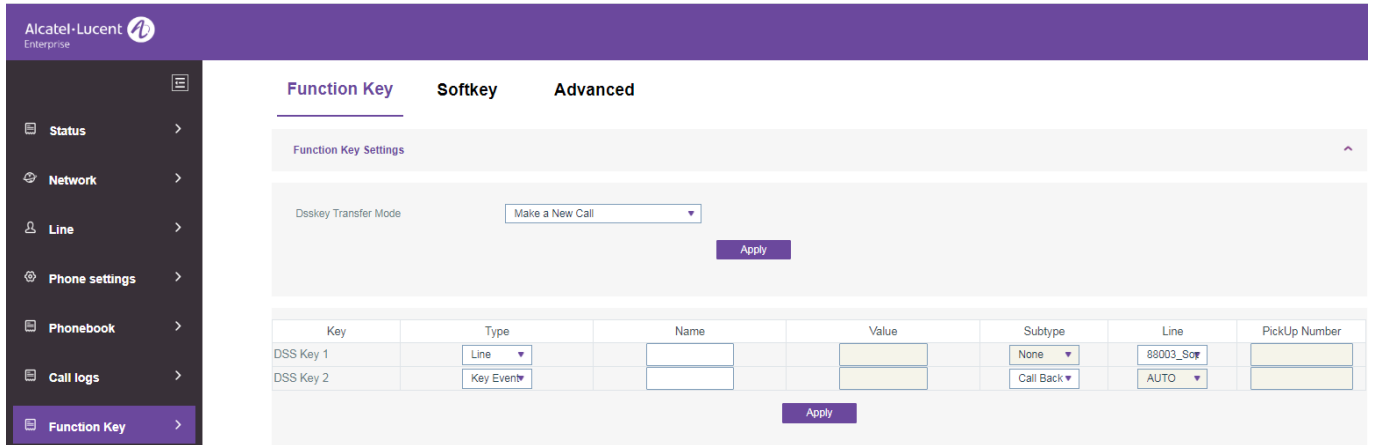

Figure 24 - Set the callback key on the web page

8.7 Mute

You can turn on Mute mode during a call and turn off the microphone so that the local voice is not heard. Normally, Mute mode is automatically turned off at the end of a call. You can also turn on Mute at any time and mute the ringtone automatically when there is an incoming call. Mute mode can be turned on in all call modes (handset, headphones or hands-free).

8.7.1 Mute the call



- During the conversation, press the Mute button  on the telephone. The Mute button on the telephone will turn on the red light. The Mute icon is displayed in the call interface, as shown in the figure below:



Figure 25 - Mute the call

- Cancel Mute: Press  Cancel Mute on the telephone again. The Mute icon is no longer displayed on the call screen.

8.7.2 Ringing Mute





- Mute: Press the Mute button when the telephone is in Standby mode: . The top right corner of the telephone screen shows the Bell Mute icon . The red light for the Mute button is always on. When there is an incoming call, the telephone will display the incoming call interface but will not ring.



Figure 26 - Ringing mute

- Cancel ring tone mute: On the Standby or Incoming Call screen, press the Mute button  again or volume up  to cancel ring tone mute. The Mute icon is no longer shown in the upper right corner after cancelling . The telephone mute icon is off.

8.8 Hold/resume call

The user can press the **[Hold]** button to maintain the current call, and this button will become the **[Resume]** button. The user can press the “resume” button to restore the call. Sometimes you need to press the **[More]** button to find the **[Hold]** or **[Resume]** button.



Figure 27 - Call hold interface

8.9 DND

The user may enable the Do-Not-Disturb (DND) feature on the device to reject incoming calls (including call waiting). The DND can be enabled on a line basis.

To enable/disable all lines DND on the telephone, use one of the following methods:

- Telephone interface: default Standby mode,
 - 1) Press the **[DND]** button to enter the DND setting interface, select the line or telephone to enable DND.
 - 2) Press the **[DND]** button to enter the DND setting interface and disable DND.

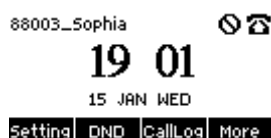

Figure 28 - Enable DND

If the user wants to enable/disable uninterrupted function on a specific line, the user can set the uninterrupted function on the line configuration page.

- 1) Press the **[Setting]** >> **[Phone]** >> **[DND]** button, Enter **[DND]** to edit the interface.
- 2) Click the left/right navigation button to select the line on which the mode is to be adjusted and the status changed to “Do Not Disturb”, and then press the **[OK]** button to save.

The user will see the DND icon, and “DND” mode has been enabled on the telephone or SIP line.

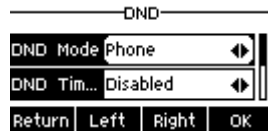

Figure 29 - DND setting interface

The user can also use the DND timer. After setting, the DND function will automatically turn on during that time range.

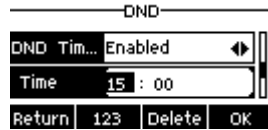

Figure 30 - DND timer

- WEB interface: Enter [**Phone setting**] >> [**Features**] >> [**DND settings**], set the DND Option (off, phone, line), and the DND Timer information.

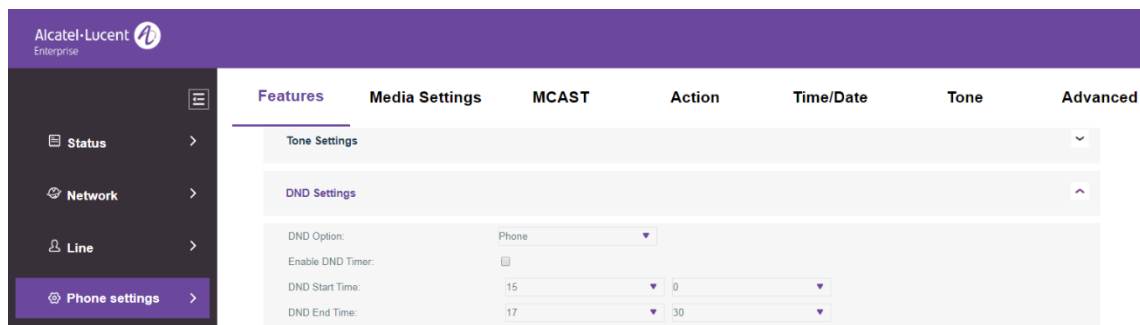

Figure 31 - DND settings

The user turns on the DND for a specific route on the web page: Enter [**Line**] >> [**SIP**], select a [**Line**] >> [**Basic settings**], and enable DND.

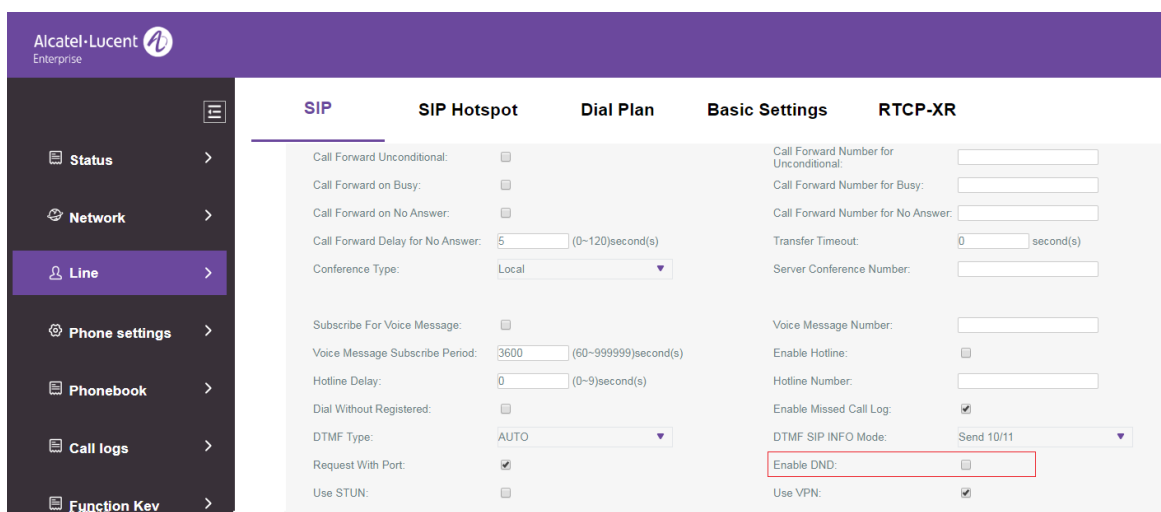

Figure 32 - Line DND

8.10 Call forwarding

Call forwarding is also known as ‘Call Divert,’ which means to divert the incoming call to a specific number based on set conditions and configurations. The user can configure the call forwarding settings of each line. There are three types:

- **Unconditional Call Forward** - Forward any incoming call to the configured number.
- **Call Forward on Busy** - When the user is busy, the incoming call will be forwarded to the configured number.
- **Call Forward on No Answer** - When the user does not answer the incoming call after the configured delay time, the incoming call will be forwarded to the configured number.
- WEB interface: Enter [**Line**] >> [**SIP**], Select a [**Line**] >> [**Basic settings**], and set the type, number and time of forwarding.

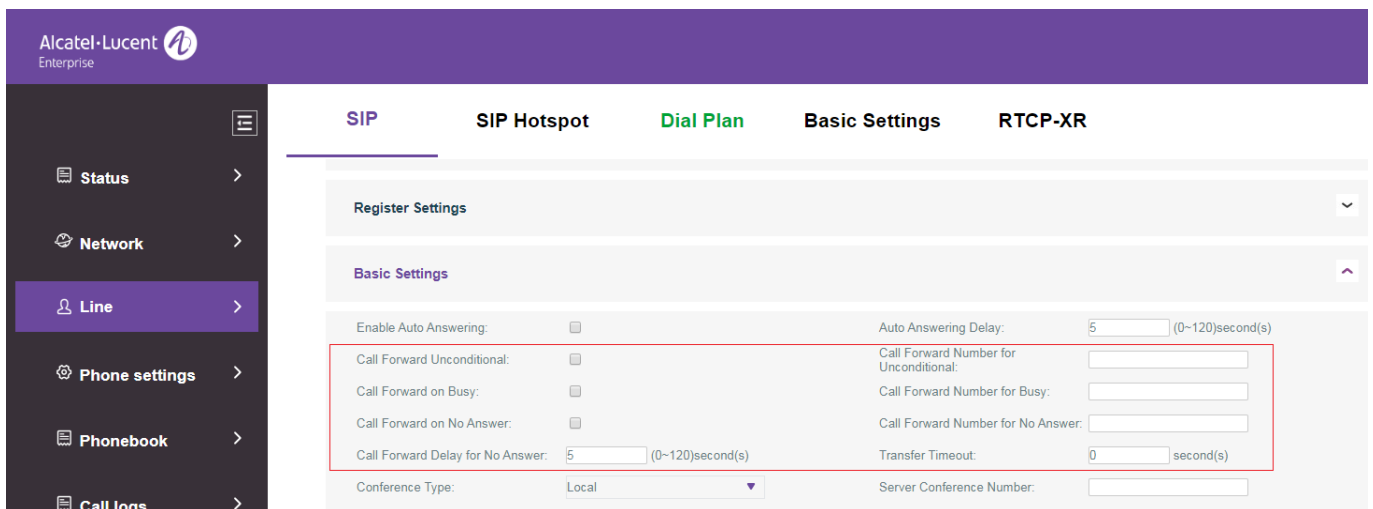

Figure 33 - Set call forwarding

8.11 Call transfer

When the user is talking with a remote party and wishes to transfer the call to another remote party, there are three ways to transfer the call: blind transfer, attended transfer and semi-attended transfer.

- Blind transfer: No need to negotiate with the other side. Directly transfer the call to the other side.
- Semi-attended transfer: When you hear the ring back, transfer the call to the other party.
- Attended transfer: When the caller answers the call, transfer the call to the other party.

Note: For more transfer settings, please refer to [12.5 Line >> Dial Plan](#)

8.11.1 Blind transfer



During the call, the user presses the function menu button [**XFER**] or the transfer button  on the telephone, Enter the number to transfer or press the contact button or the history button to select the number, press the [**XFER**] key or  again to blind transfer to a third party. After the third party rings, the telephone will show that the transfer is successful and hang up.



Figure 34 - Transfer interface

8.11.2 Semi-attended transfer

During the call, the user presses the function menu button [**XFER**] or the transfer button  on the telephone to input the number to be transferred or presses the Redial button to select the number, and then presses the [**Dial**] button. If the third party does not answer, press the [**XFER**] button on the call interface to make the semi-attended transfer or press the [**End**] button to cancel the semi-attended transfer.



Figure 35 - Semi-attended transfer

8.11.3 Attended transfer

An attended transfer is also known as “courtesy mode”, which means that the call is transferred by calling the other party and waiting for the other party to answer the call.

Use the same procedure in a call. In dual call mode, press the [**XFER**] button to transfer the first call to the second call.



Figure 36 - Attended transfer

8.12 Call waiting

- Enable call waiting: New calls can be accepted during a call.
- Disable call waiting: New calls will be automatically rejected and a busy tone will be prompted.
- Enable call waiting tone: When you receive a new call on the line, the tone will beep.
- The user can enable/disable the call waiting function in the telephone interface and the web interface.
- WEB interface: Enter [**Phone Settings**] >> [**Features**] >> [**Basic Settings**], enable/disable call waiting and call waiting tone.

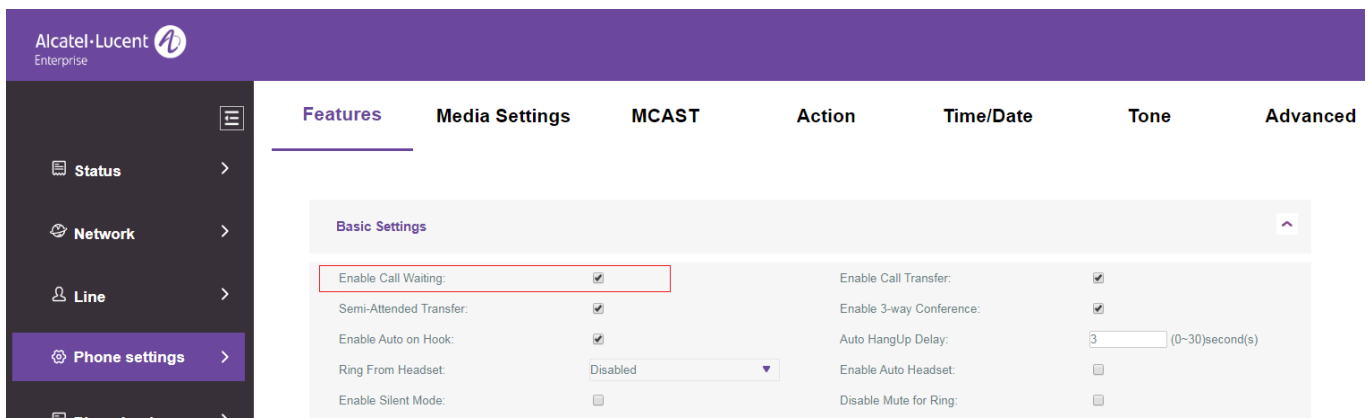

Figure 37 - Web call waiting setting

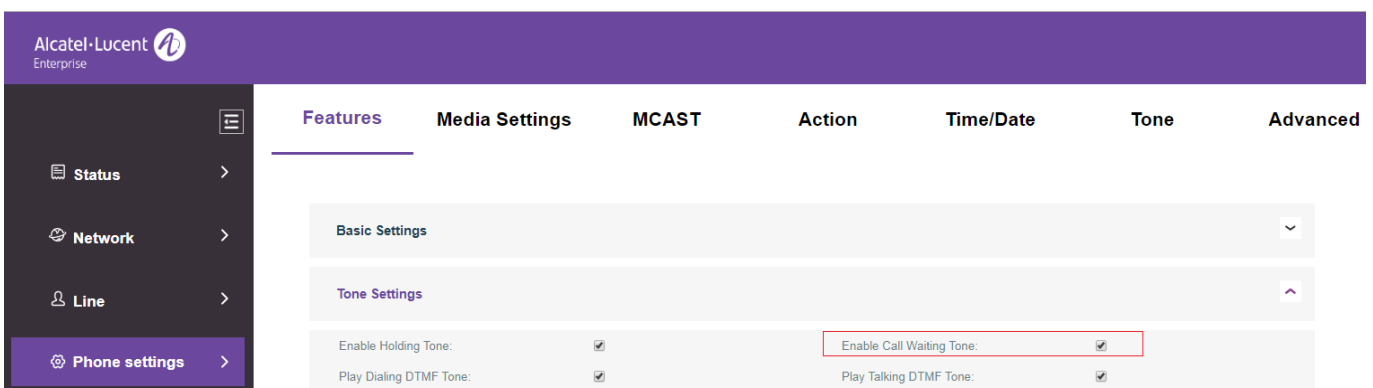

Figure 38 - Web call waiting tone setting

8.13 Conference

8.13.1 Local conference

To conduct a local conference, the user needs to log in to the webpage and enter [Line] >> [SIP] >> [Basic settings]. The Meeting mode is set as local (the default is local mode), as shown in the figure:

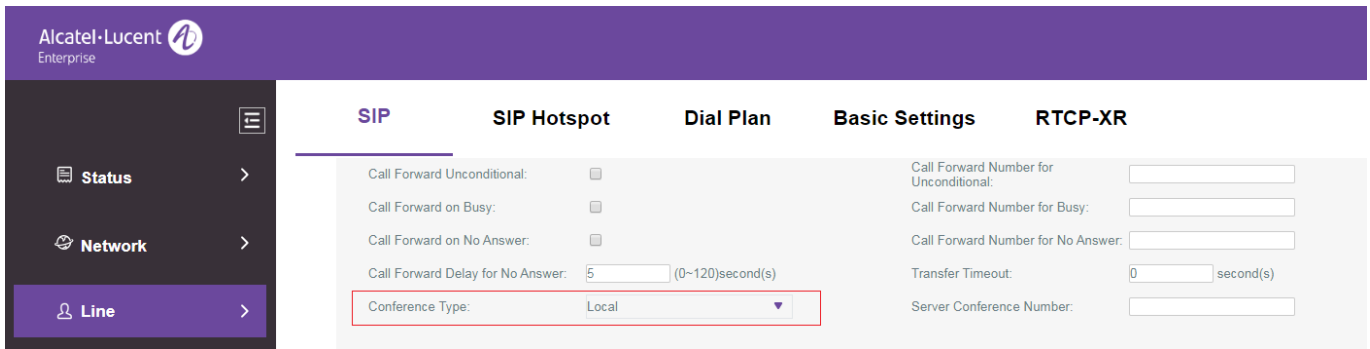

Figure 39 - Local conference setting

Two ways to create a local conference:

- 3) The device has two channels of communication. Press the conference button on the call interface. When selecting the conference number, select the other number that already exists. Press the OK key to start the conference.



Figure 40 - Local conference (1)

- 4) If the device has a call all the way, press the conference key in the call interface, enter the number to join the meeting, and press the call. After the other end has answered, press the conference button again to set up the local tripartite conference:



Figure 41 - Local conference (2)

Note: During the conference, press the split button to split the conference and press the end button to end the call.

8.13.2 Network conference

Users need server support for network conference.

Log in to the web page, enter **[Line]** >> **[SIP]** >> **[Basic settings]**, set the conference mode as server mode (default is local mode), set the server conference room number (please consult your system administrator), as shown in the figure below:

The screenshot shows the Alcatel-Lucent Enterprise web interface. The top navigation bar is purple with the Alcatel-Lucent logo and 'Enterprise' text. Below the navigation bar, there are several tabs: 'SIP', 'SIP Hotspot', 'Dial Plan', 'Basic Settings', and 'RTCP-XR'. The 'Basic Settings' tab is selected. The settings are organized into two columns. The left column includes: 'Call Forward Unconditional:' with a checkbox, 'Call Forward on Busy:' with a checkbox, 'Call Forward on No Answer:' with a checkbox, and 'Call Forward Delay for No Answer:' with a text input field containing '5' and '(0-120)second(s)'. The right column includes: 'Call Forward Number for Unconditional:' with a text input field, 'Call Forward Number for Busy:' with a text input field, 'Call Forward Number for No Answer:' with a text input field, 'Transfer Timeout:' with a text input field containing '0' and 'second(s)', and 'Server Conference Number:' with a text input field containing '1234'. A red box highlights the 'Conference Type:' dropdown menu, which is set to 'Server', and the 'Server Conference Number:' input field.

Figure 42 - Network conference

Method for joining a network conference:

- Multi-party call number for a network conference room: Enter the password, and then all parties enter the conference room.
- The two telephones have established common calls. Press the conference button to invite new members to the conference. Follow the voice prompt to operate.

Note: The upper limit of the number of participants in the network conference varies depending on the server.

8.14 Call park

A call park requires server support. Consult your system administrator for support.

When you are on the call, if it is not convenient to answer the telephone at that time, you can press the configured Park button to hold the call. After a successful park, you can resume the call by pressing the configured Park button on other devices.

Set the Call Park button:

- Telephone interface: Long press a function key to enter the function key Settings interface, and set the key function type as Memory Key and subtype as Call Park, set the values for the server call park number, and set up the corresponding SIP lines.
- WEB interface: Log in to the telephone page, enter the **[Function Key]** >> **[Function Key]** page, select a DSSkey, set the key function type as Memory Key and subtype as Call Park, set the value as the call park number of the server, and set up the corresponding SIP line.

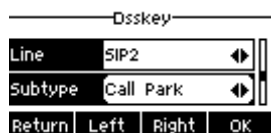

Figure 43 - Setting Call Park in telephone

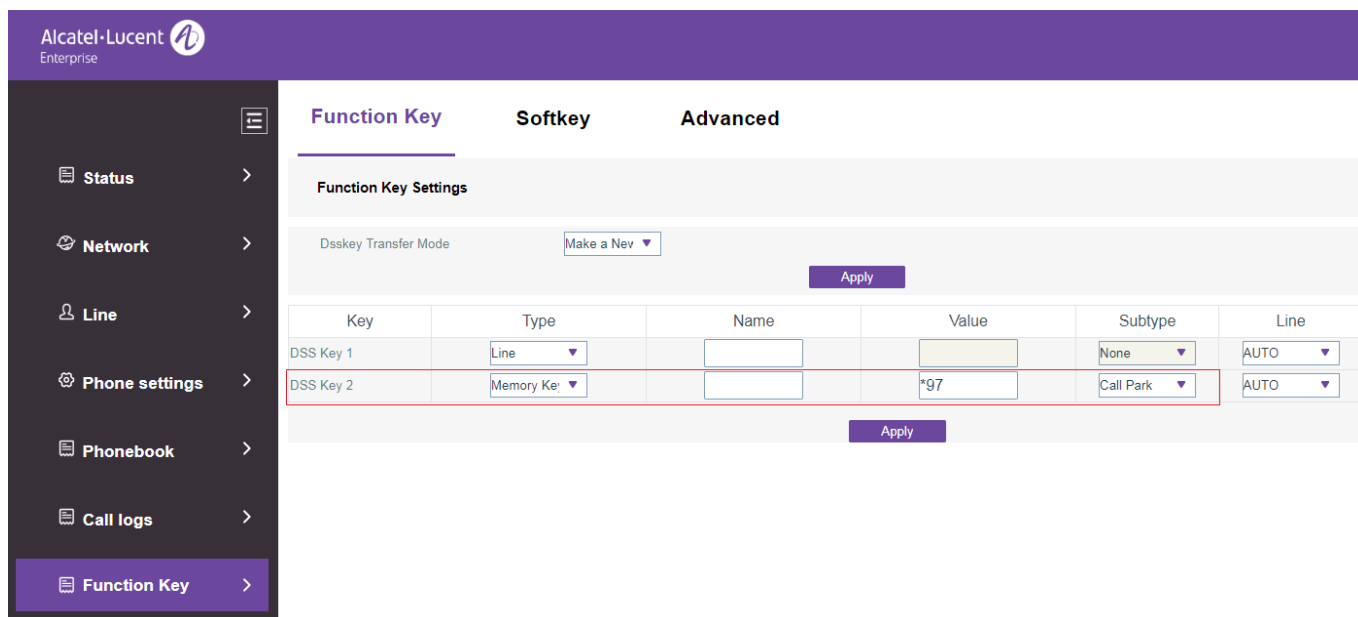

Figure 44 - Setting Call Park in web

8.15 Pick up

Pick up requires server support. Consult your system administrator for support.

You can use the Pick Up function to answer incoming calls from other users. The telephone can pick up incoming calls by configuring the DSSkey for BLF and setting the Pick Up code.

Telephone interface: Long press the line key to enter the **[DssKey]** setting interface, and select a Dsskey to set.

- Set the line, function key type as Memory Key, subtype as BLF/NEW CALL, subscription number, and pick up code
- Other telephones call the subscription number, and the opposite end is in the incoming ring.
- Press the DSS key to pick up the telephone.
- The caller picks up the call and speaks.



Figure 45 - Setting Pick Up on the telephone

WEB interface: Log in to the telephone web page, enter the **[Function Key]** >> **[Function Key]** page, select a DSSkey, set the memory key type as Memory Key, the subtype as BLF/NEW CALL, and set up the corresponding SIP line and Pick Up codes.

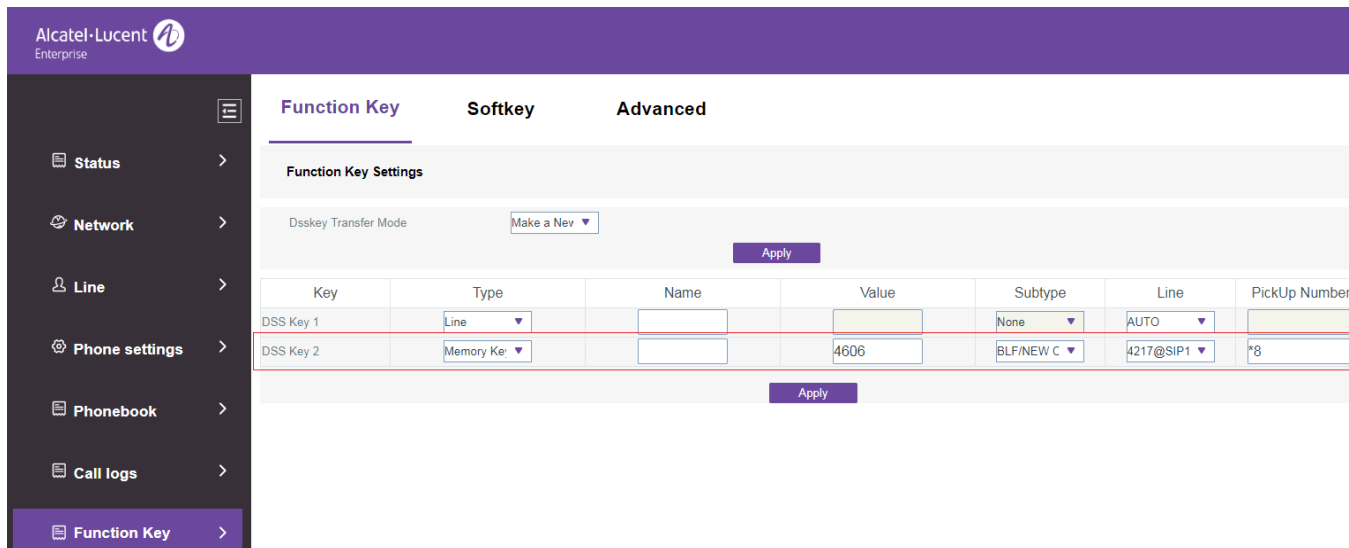

Figure 46 - Setting Pick Up on the web

8.16 Anonymous call

8.16.1 Anonymous call

The telephone can set up anonymous calls to hide the calling number and the calling name.

- The web page [Line] >> [SIP] >> [Advanced Settings] can also be used to open the Anonymous Call mode.
- A setting to enable anonymous calls also corresponds to the SIP line. That is, a setting on the SIP1 page can only take effect on the SIP1 line.

Figure 47 - Enabling an anonymous web page call

The following is a transcript of an anonymous call received by the telephone.

```

    ← All →
    [Phone] Anonymous 06 Jan 23:55
    |
    [Return] [Option] [Delete] [Dial]
  
```

Figure 48 - Anonymous call log

8.16.2 Banning anonymous calls

The device can be set to prohibit anonymous calls, that is, anonymous calls to the number will be directly rejected.

- In the telephone, go to [Setting] >> [Phone] >> [Anonymous], click to enter, and all SIP lines will be displayed.
- Click Softkey [Switch] or [<] [>] to switch the SIP line and enable anonymous calls.

Figure 49 - Anonymous calls are not allowed on the telephone

- On the web page, go to [Line] >> [SIP] >> [Advanced Settings], where you can also disable anonymous calls.
- The setup to disable anonymous calls also corresponds to the SIP line. That is, settings on the SIP1 page can only take effect on the SIP1 line.

Enable Session Timer:	<input type="checkbox"/>	Session Timeout:	<input type="text" value="0"/> second(s)
Enable BLF List:	<input type="checkbox"/>	BLF List Number:	<input type="text"/>
Response Single Codec:	<input type="checkbox"/>	BLF Server:	<input type="text"/>
Keep Alive Type:	UDP	Keep Alive Interval:	<input type="text" value="30"/> second(s)
Keep Authentication:	<input type="checkbox"/>	Blocking Anonymous Call:	<input checked="" type="checkbox"/>
RTP Encryption(SRTP):	Disabled		

Figure 50 - Page settings for blocking anonymous calls

8.17 Hotline

The device supports hotline dialing. After setting up hotline dialing, pick up the handset, use hands-free, earphone, etc., and the telephone will automatically call according to the hotline delay time.

- In the telephone. Go to **[Setting]** >> **[Phone]** >> **[Hotline]**, click to enter, and all SIP lines will be displayed.
- Then set the hotline for each SIP line, which is off by default.
- Open the hotline, set the hotline number, set the delay time of the hotline.

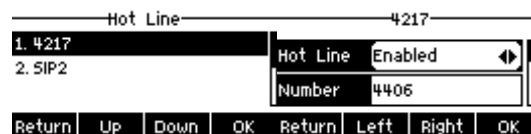

Figure 51 - Telephone hotline setting interface

- On the website, go to **[Line]** >> **[SIP]** >> **[Basic Settings]**. Here, you can also set up a hotline.
- The setup hotline also corresponds to the SIP line. That is, the hotline set on the SIP1 web page can only be activated on the SIP1 line.

Subscribe For Voice Message:	<input type="checkbox"/>	Voice Message Number:	<input type="text"/>
Voice Message Subscribe Period:	<input type="text" value="3600"/> (60~999999)second(s)	Enable Hotline:	<input checked="" type="checkbox"/>
Hotline Delay:	<input type="text" value="0"/> (0~9)second(s)	Hotline Number:	<input type="text" value="4406"/>
Dial Without Registered:	<input type="checkbox"/>	Enable Missed Call Log:	<input checked="" type="checkbox"/>
DTMF Type:	AUTO	DTMF SIP INFO Mode:	Send 10/11
Request With Port:	<input checked="" type="checkbox"/>	Enable DND:	<input type="checkbox"/>
Use STUN:	<input type="checkbox"/>	Use VPN:	<input checked="" type="checkbox"/>

Figure 52 - Hotline set up on web page

8.18 Emergency call

The Emergency Call function is used to enter the corresponding emergency call number on the telephone after enabling the keypad lock. You can also call emergency services when your telephone is locked.

- 1) Configure the emergency call number: Log in to the telephone page, enter [**Phone Settings**] >> [**Function Settings**], select [**Basic Settings**], and set up the emergency call code. If you need to set up more than one emergency call code, please use “,” to separate them.

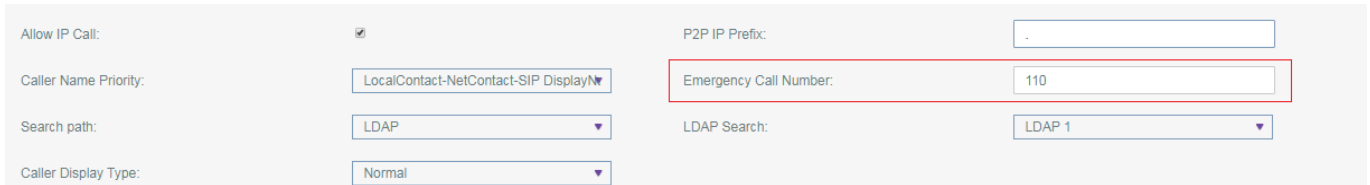

The screenshot shows a settings page with several fields. The 'Emergency Call Number' field is highlighted with a red border and contains the value '110'. Other fields include 'Allow IP Call' (checked), 'P2P IP Prefix' (empty), 'Caller Name Priority' (LocalContact-NetContact-SIP Display), 'Search path' (LDAP), 'Caller Display Type' (Normal), and 'LDAP Search' (LDAP 1).

Figure 53 - Setting up an emergency call number

- 2) When the keyboard lock is set on the telephone, you can call the emergency call number without unlocking, as shown in the figure below:



Figure 54 - Dial the emergency number

9 Advance Function

9.1 BLF (Busy Lamp Field)

9.1.1 Configure the BLF functionality

- Page interface: Log in to the telephone page, enter the [Function key] >> [Function key] page, select a DSS key, set the function key type as Memory Key, choose the subtype from among BLF/NEW CALL, BLF/BXFER, BLF/AXFER, BLF/CONF, set the BLF/DTMF value as the number to be subscribed, and set the corresponding SIP line. The pickup number is provided by the server. For specific usage, refer to [8.15 Pick up](#).

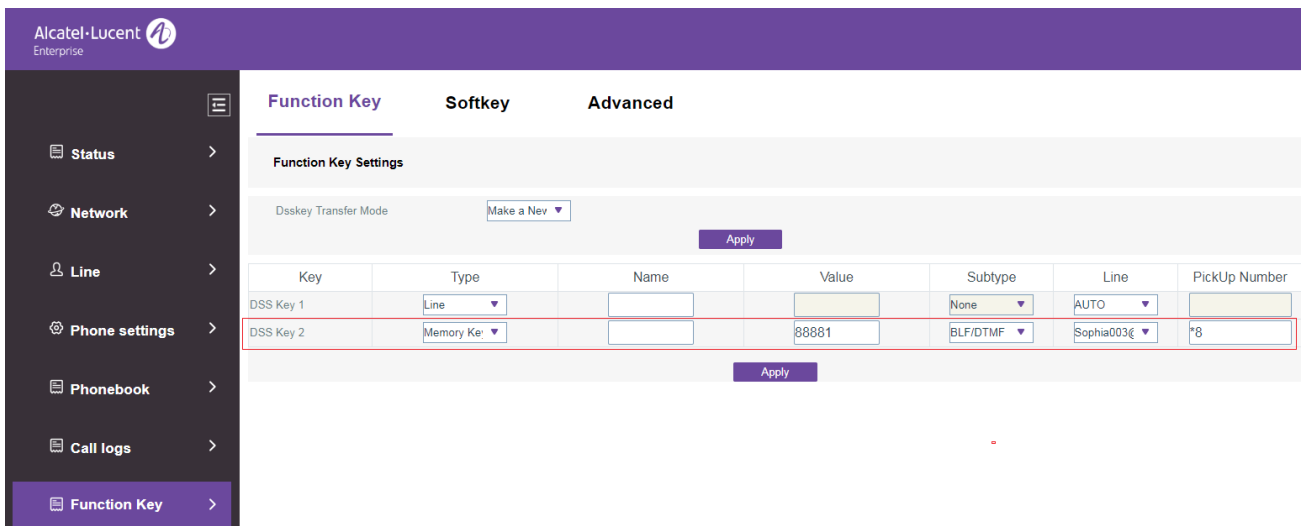

Figure 55 - Web page configuration of BLF function key

- Telephone interface: Long press a function key to enter the function key Settings interface, set the key function types as memory keys and the subtype as BLF/NEW CALL, BLF/BXFER, BLF/AXFER, BLF/CONF, or BLF/DTMF. The value is the subscription number. Set up the corresponding SIP lines.



Figure 56 - Telephone configuration of BLF function key

Table 8 - BLF Function Key Subtype Parameter List

Subtype	Standby is described	Calling is described
BLF/NEW CALL	Pressing the BLF key while in standby to dial the subscriber number.	When you press this BLF key while talking to another user, you create a new call along with the subscribed number.

Subtype	Standby is described	Calling is described
BLF/BXFER	Pressing the BLF key while in standby to dial the subscriber number.	When you press this BLF key while talking to another user, you blind transfer the call to the subscribed number.
BLF/AXFER	Pressing the BLF key while in standby to dial the subscriber number.	When you press this BLF key while talking to another user, you make an attended transfer of the call to the subscribed number.
BLF/ Conference	Pressing the BLF key while in standby to dial the subscriber number.	When you press this BLF key while talking to another user, you invite the subscriber number to join the meeting.
BLF/DTMF	Pressing the BLF key while in standby to dial the subscriber number.	When the BLF key is pressed while talking to another user, the telephone automatically sends the DTMF corresponding to the BLF key number.

9.1.2 Using the BLF function

The BLF, also known as a “busy light field,” notifies the user of the status of the subscribed object and is used by the server to pick up the call. BLF helps you monitor the other person’s status (idle, ringing, talking, off).

The BLF function:

- Monitors the status of subscribed telephones.
- Calls the subscribed number.
- Transfers calls to the subscribed number.
- Picks up incoming calls from the subscribed number.

1) Monitoring the status of subscribed telephones.

Configuration of BLF function keys: When the subscribed number’s status (idle, ringing, talking) changes, the function key’s LED lights will show a corresponding change. See [6.3 Appendix III - LED Definition](#) to learn about the different status LEDs.

2) Calling the subscribed number.

When the telephone is in Standby mode, press the configured BLF key to call out to the subscribed number.

3) Transferring calls to the subscribed number.

Refer to [Table 8 - BLF Function Key Subtype Parameter List](#). The BLF key can be used for blind transfers, attended transfers, and semi-attended transfers of the current call, and can also invite the subscribed number to join the call, send a DTMF, etc.

4) Picking up incoming calls from subscribed telephones.

When configuring the BLF function key, configure the pickup number.

When the telephone with the subscribed number rings (refer to [6.3 Appendix III - LED Definition](#)), the LED will turn red at this time. At this point, press the BLF button to answer the incoming call from the subscribed number.

9.2 BLF List

The BLF List key is for putting the number to be subscribed into a group on the server side, and the telephone uses the URL of this group to make a unified subscription. The specific information, number, name and status of each number can be resolved based on notifications sent from the server. The unoccupied Memory Key is then set as the BLF List key. If the status of the subscription object changes later, the corresponding status of the LED light will be changed.

Configuring the BLF List function: Log in to the telephone page, enter the **[Line]** >> **[SIP]** >> **[Advanced settings]** page, enable the BLF List, and configure the BLF List number.

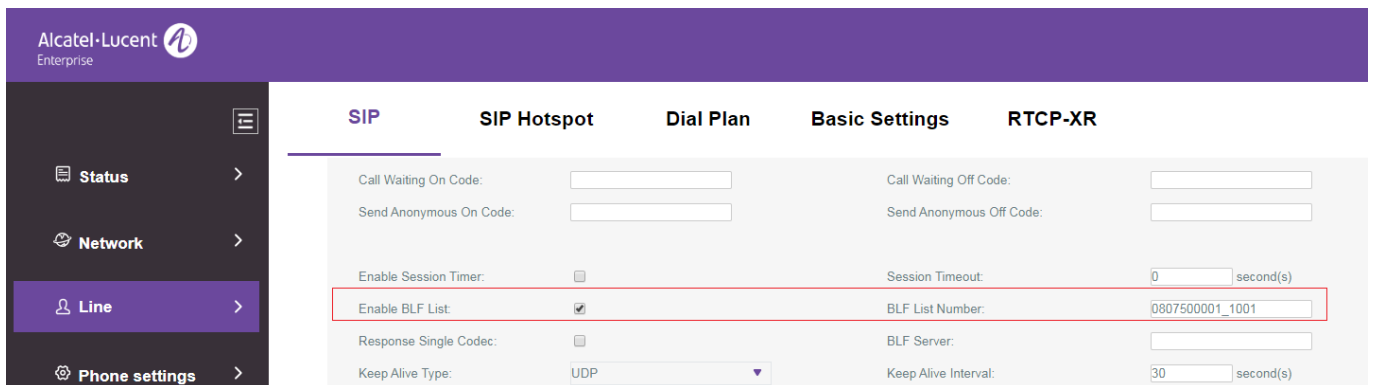
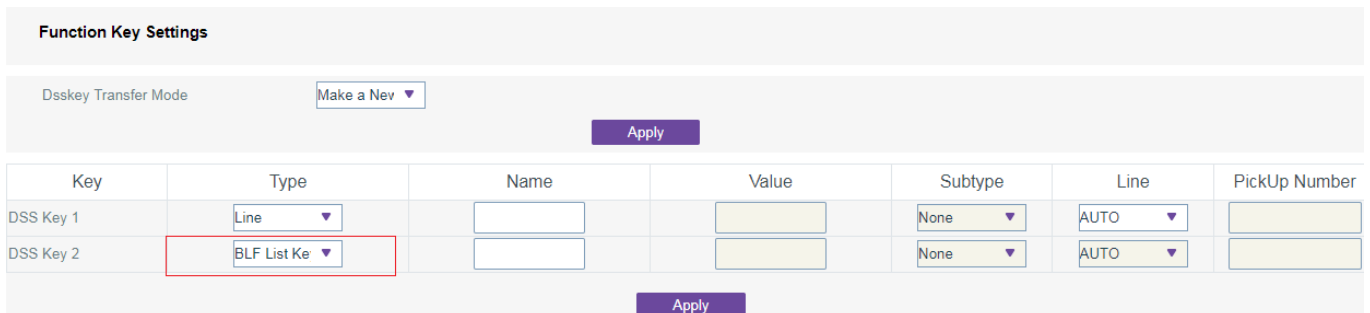

Figure 57 - Configuring the BLF List functionality

Using the BLF List function: When the configuration is completed, the telephone will automatically subscribe to the contents of the BLF List group. Users can monitor, call and transfer the corresponding number by pressing the BLF List key.



Key	Type	Name	Value	Subtype	Line	PickUp Number
DSS Key 1	Line			None	AUTO	
DSS Key 2	BLF List Ke			None	AUTO	

Figure 58 - BLF List number display

9.3 Record

The device supports recording during a call.

9.3.1 Recording from the server

When using the network server to record, it is necessary to open the recording on the telephone web page **[Application]** >> **[Manage recording]**. The type is selected as network, and the address and port of the recording server are filled in, and then the voice coding is selected. The web page appears as below:

The screenshot shows a web interface titled "Record Setting". It contains the following fields and controls:

- Enable Record:** A checkbox that is checked.
- Record Type:** A dropdown menu with "Network" selected.
- Voice Codec:** A dropdown menu with "PCMU" selected.
- Server Address:** A text input field containing "172.24.213.79".
- Server Port:** A text input field containing "10001".
- Apply:** A purple button located below the input fields.

Figure 59 - Web server recording

Note: Recording software from the vendor is needed to make recordings via the server.

9.3.2 SIP INFO recording

The telephone is registered with a server that supports SIP INFO recording. After registering the account, check the recording module via **[Application]** >> **[Manage recording]** to open the recording. The recording type is SIP INFO.

The screenshot shows a web interface titled "Record Setting". It contains the following fields and controls:

- Enable Record:** A checkbox that is checked.
- Record Type:** A dropdown menu with "Sip Info" selected.
- Apply:** A purple button located below the input fields.

Figure 60 - Web SIP info recording

9.4 Agent

Using the Agent function of the telephone: When multiple people use a device for Agent services at different times, he or she can quickly register his or her SIP account on the same server. The Agent functions of the telephone are Normal and Hotel Guest. The Hotel Guest mode requires server support.

Normal Mode:

Configuring the Agent function: Long press the line key to enter the **[Dsskey]** interface. Set type as Key Event, Key as Agent, and then press OK to set a DSSkey as the **[Agent]** key.

Press the [**Agent**] key to enter the [**Agent**] page. The SIP server needs to be configured before the account can be configured.

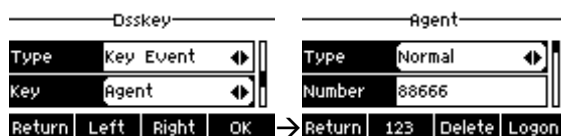

Figure 61 - Configuring the Agent account in Normal mode



Figure 62 - Configuring the proxy account - Hotel Guest mode

Table 9 - Agency mode

Parameter	Description
Normal mode	
Number	Set the proxy account number.
User	Set the proxy account number to verify the user name.
Password	Set the proxy account number to verify the password.
Line	Select the SIP line.
Call Log	Users can choose to save all types, or delete.
Hotel Guest mode	
Number	Set the proxy account number.
Password	Set the proxy account number to verify the password.
Line	Select the SIP line.
Call Log	Users can choose to save all types, or delete.

Using agent functions:

- 1) When the telephone has been configured on an SIP server, fill in the the correct number, user name and password, click login, and then the telephone can be registered to the SIP server;
- 2) After registration, click logoff, and the telephone can delete the user name and password, and log out of the SIP account.
- 3) If you click Unregister, the telephone retains the user name and password and logs out of the SIP account.

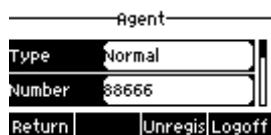

Figure 63 - Agent logon page

9.5 Intercom

When the Intercom is enabled, it can automatically receive calls from the intercom.

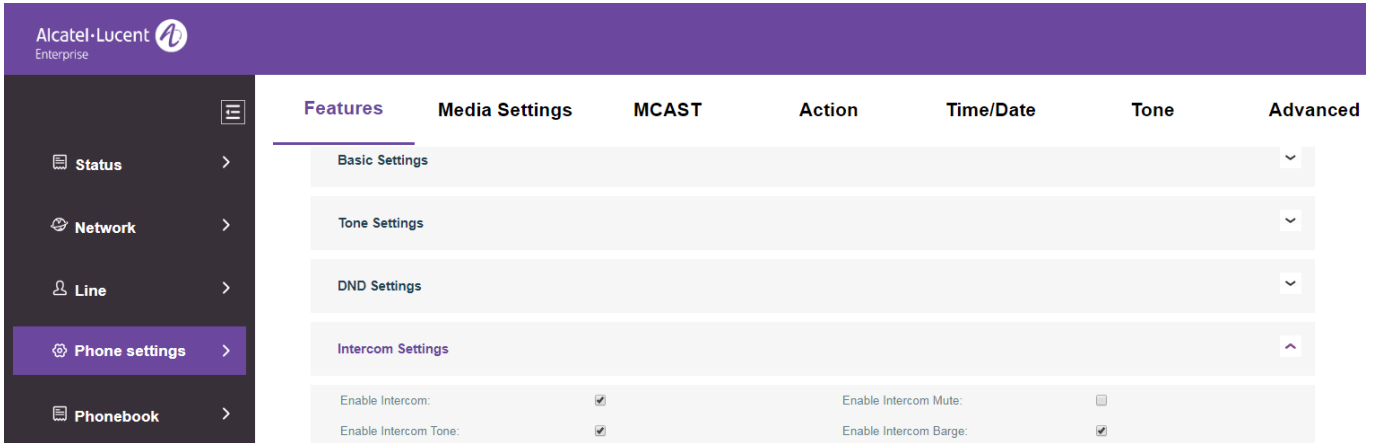

Figure 64 - Configuring the intercom on the Web

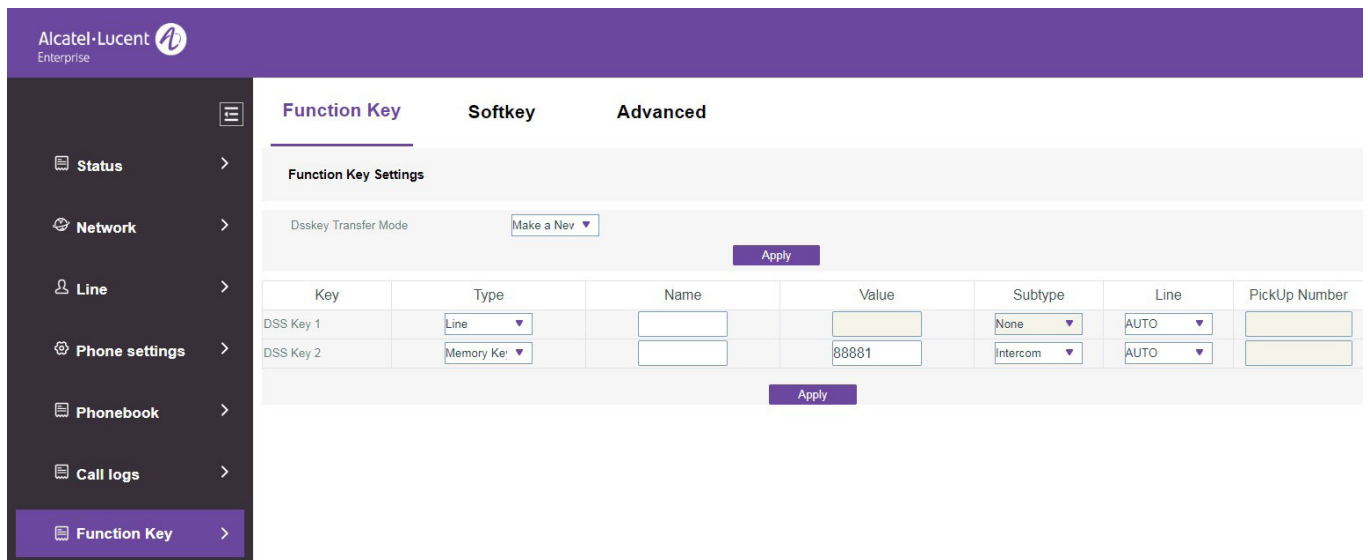

Figure 65 - Configuring the Intercom key on the web

Table 10 - Intercom Configuration

Parameter	Description
Enable Intercom	When the intercom is enabled, the device will accept the incoming call request with a SIP header of Alert-Info instructions to automatically answer the call after a specific delay.
Enable Intercom Mute	Enabling Mute mode during the intercom call
Enable Intercom Tone	If the incoming call is an intercom call, the telephone plays the intercom tone
Enable Intercom Barge	Enabling Intercom Barge by selecting it, the telephone auto answers the intercom call during a call. If the current call is an intercom call, the telephone will reject the second intercom call.

9.6 MCAST

This feature allows the user to make some kind of broadcast call to people who are in a multicast group. The user can configure a multicast DSS Key on the telephone which allows the user to send a Real Time Transport Protocol (RTP) stream to the pre-configured multicast address without involving SIP signaling.

You can also configure the telephone to receive an RTP stream from a pre-configured multicast listening address without involving SIP signaling. You can specify up to 10 multicast listening addresses.

Multicast:

- On the web page, go to **[Function Key]** >> **[Function Key]**, select the type of multicast, set the multicast address, and select the codec.
- Set the IP address and port number for multicast listening, to be separated by a colon (IP address range is 224.0.0.0 to 239.255.255.255, port number range is preferably between 1024 and 65535).

Key	Type	Name	Value	Subtype	Line	PickUp Number
DSS Key 1	Line ▼	<input type="text"/>	<input type="text"/>	None ▼	88881_Da▼	<input type="text"/>
DSS Key 2	MCAST Pa▼	<input type="text"/>	239.1.1.4:136▼	G.711U ▼	AUTO ▼	<input type="text"/>

Figure 66 - Setting the Multicast function key

- Click Apply.
- Set up the name, host and port of the multicast to be received on the web page by going to **[Phone Settings]** >> **[MCAST]**.

Alcatel-Lucent  Enterprise

- Status >
- Network >
- Line >
- Phone settings >
- Phonebook >
- Call logs >

Features Media Settings MCAST Action Time/Date Tone Advanced

MCAST Listening ▲

Priority: ▼

Enable Page Priority:

Enable Prio Chan:

Enable Emer Chan:

Index/Priority	Name	Host:port	Channel
1	<input type="text"/>	<input type="text" value="239.1.1.4:1369"/>	<input type="text" value="0"/> ▼

Figure 67 - Multicast settings page

Table 11 - MCAST Parameters on the Web

Parameters	Description
Normal Call Priority	Define the priority of the active call: 1 is the highest priority, 10 is the lowest.
Enable Page Priority	The voice call in progress shall take precedence over all incoming paging calls.
Name	Server name of the multicast to be listened to.
Host:port	Server's multicast IP address and port for the multicast to be listened to.

- Press the DSS KEY of Multicast Key which you set.
- The receiving end will receive the multicast call and play the multicast automatically.

9.7 SCA (Shared Call Appearance)

Users need the support of the server end to use the SCA function. Here is an example of a BroadSoft server.

1) Configuring on the telephone.

- When registering with the BroadSoft server, a telephone can register the account created previously on multiple terminals.

The screenshot displays a SIP configuration page. At the top, 'Line Status' is 'Registered' and 'Activate' is checked. The 'Username' field contains '9736722021'. The 'Authentication User' field contains 'u9736722021'. The 'Authentication Password' field contains '*****'. The 'Server Name' field is empty. Below these, 'SIP Server 1:' is selected, and its 'Server Address' field contains 'broadsoftlab.com'. Other fields for 'SIP Server 1:' include 'Server Port' (5060), 'Transport Protocol' (UDP), and 'Registration Expiration' (3600 second(s)). A second 'SIP Server' section is also visible but mostly empty. Red boxes and arrows point from the labels 'SCA number', 'SCA sip username and password', and 'Broadsoft sip server address' to their respective fields in the configuration.

Figure 68 - Registering a BroadSoft account

- After the telephone set registers with the BroadSoft server, a server type needs to be set. Specifically, log in to the web page of the telephone set, choose [Line] >> [SIP] >> [Advanced Settings] and set Specific Server Type to BroadSoft, as shown in the following figure.

The screenshot shows a configuration page for SIP settings. The 'Specific Server Type' dropdown menu is highlighted with a red box and is set to 'BroadSoft'. Other visible settings include: 'Enable BLF LIST' (checked), 'Response Single Codec' (unchecked), 'Keep Alive Type' (UDP), 'Keep Alive Interval' (30 second(s)), 'Keep Authentication' (unchecked), 'Blocking Anonymous Call' (unchecked), 'RTP Encryption(SRTP)' (Disabled), 'User Agent' (empty), 'SIP Version' (RFC3261), 'Local Port' (5060), 'Anonymous Call Standard' (None), 'Ring Type' (Default), 'Enable user=phone' (unchecked), 'Auto TCP' (unchecked), 'Use Tel Call' (unchecked), and 'Enable PRACK' (unchecked).

Figure 69 - Setting the BroadSoft server

Note: If the server you are using is not a BroadSoft server, you do not need to select a server type.

- If you need to enable the SCA function on an IP telephone, log in to the web page of the telephone set, choose **[Line]** >> **[SIP]** >> **[Advanced Settings]**, and select Enable SCA. If SCA is not enabled, the registered line is the private line.

The screenshot shows a configuration page for SIP settings. The 'Enable SCA' checkbox is highlighted with a red box and is checked. Other visible settings include: 'Enable Rport' (checked), 'DNS Mode' (A), 'Enable Long Contact' (unchecked), 'Enable Strict Proxy' (checked), 'Convert URI' (checked), 'Use Quote in Display Name' (unchecked), 'Enable GRUU' (unchecked), 'Sync Clock Time' (unchecked), 'Enable Use Inactive Hold' (unchecked), 'Caller ID Header' (PAI-RPID-FROM), 'Use 182 Response for Call waiting' (unchecked), 'Enable Feature Sync' (unchecked), 'TLS Version' (TLS 1.2), 'uaCSTA Number' (empty), 'Enable Click To Talk' (unchecked), 'Enable ChangePort' (unchecked), 'VQ Name' (empty), and 'VQ Server' (empty).

Figure 70 - Enabling SCA

After an account is configured and successfully registered, you can configure lines whose DSS Key is Shared Call Appearance on the Function Key page to facilitate viewing the call status of the group. Each line key represents a call appearance. Learn about call status by referring to [6.3 Appendix III - LED Definition](#).

To facilitate private holding, configure keys whose DSS Key is Private Hold on the Function Key page. Pay attention that the public hold key is the softkey-hold key during a call.

Key	Type	Name	Value	Subtype	Line	PickUp Number
DSS Key 1	Line			None	7588@SIP	
DSS Key 2	Key Event			Private Hold	SIP2	

Figure 71 - Setting the Private Hold function key

- Each telephone registered with the BroadSoft server should be configured as above; then the SCA function can be used.

2) LED status

To facilitate viewing the call status of a group, configure the DSS Key as SCA. The following table describes the LEDs of lines in different statuses.

Table 12 - LED Status of SCA

Status & Direction	Local	Remote
Idle	Off	Off
Seized	Steady blue	Steady red
Progressing (outgoing call)	Steady blue	Steady red
Alerting (incoming call)	Fast blinking blue	Fast blinking blue
Active	Steady blue	Steady red
Public Held (hold)	Slow blinking blue	Slow blinking red
Held-private (private hold)	Slow blinking yellow	Steady red
Bridge-active (Barge-in)	Steady blue	Steady red
Bridge-held	Steady blue	Steady red

3) Shared Call Appearance (SCA)

The following lists a couple of instances to facilitate understanding.

In the following scenarios, the manager and secretary register the same SCA account, and the account is configured based on the preceding steps.

Scenario 1: When this account receives an incoming call, the telephone sets of both the manager and the secretary will receive the call and ring. If the manager is busy, the manager can reject the call and the manager's telephone set stops ringing, but the secretary's telephone set keeps ringing until the secretary rejects/answers the call or the call times out.

Scenario 2: When this account receives an incoming call, if the secretary answers the call first and the manager is required to answer the call, the secretary can press the Public Hold key to hold this call and notify the manager. The manager can press the line key corresponding to the SCA to answer the call.

Scenario 3: The manager is on an important call with a customer and needs to leave for a while. If the manager does not want others to retrieve this call, the manager can press the Private Hold key.

Scenario 4: The manager is on a call with a customer and requires the secretary to join the call to make records. The secretary can press the corresponding SCA line key to join this call.

9.8 Message

9.8.1 MWI (Message Waiting Indicator)

If the service of the lines supports a voice message feature when the user is not available to answer the call, the caller can leave a voice message on the server to the user. The user will receive a voice message notification from the server, and the device will prompt a voice message waiting icon on the standby screen.



Figure 72 - New voice message notification

Voice message icon

To listen to a voice message, the user must first configure the voicemail number. After the voicemail number is configured, the user can retrieve the voicemail from the default line. When the telephone is in default standby status,

- Press  to open the voice message configuration interface, and select the line to be configured by pressing the up/down navigation buttons.
- Press the [**Edit**] button to edit the voice message number. When finished, press the [**OK**] button to save the configuration.
- In the following picture, “1” in front of the line brackets represents unread voice messages, and “4” represents the total number of voice messages.

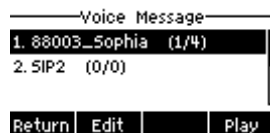

Figure 73 - Voice message interface



Figure 74 - Configuring the voicemail number

10 Telephone Settings

10.1 Basic settings

10.1.1 Language

The user can set the telephone language through the telephone interface and web interface.

- Telephone end: After resetting the factory settings, the user needs to set the language; when setting the language during standby, go to **[Menu]** >> **[Basic]** >> **[Language]** settings, as shown in the figure.



Figure 75 - Setting the telephone language

- Web interface: Log in to the telephone web page and set the language in the drop-down box at the top right corner of the page, as shown in the figure:

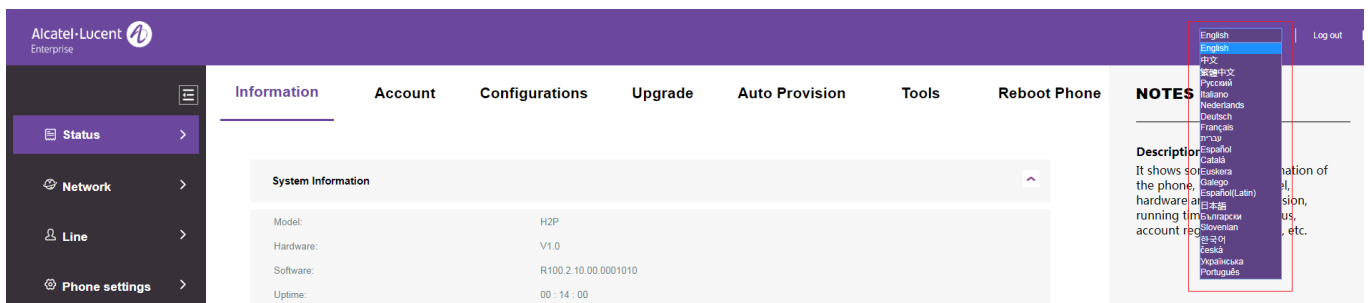

Figure 76 - Setting the language on the web page

10.1.2 Time & date

Users can set the telephone time via the web interface.

- Web interface: Log in to the telephone web page and go to **[Phone Settings]** >> **[Time/Date]**, as shown in the figure:

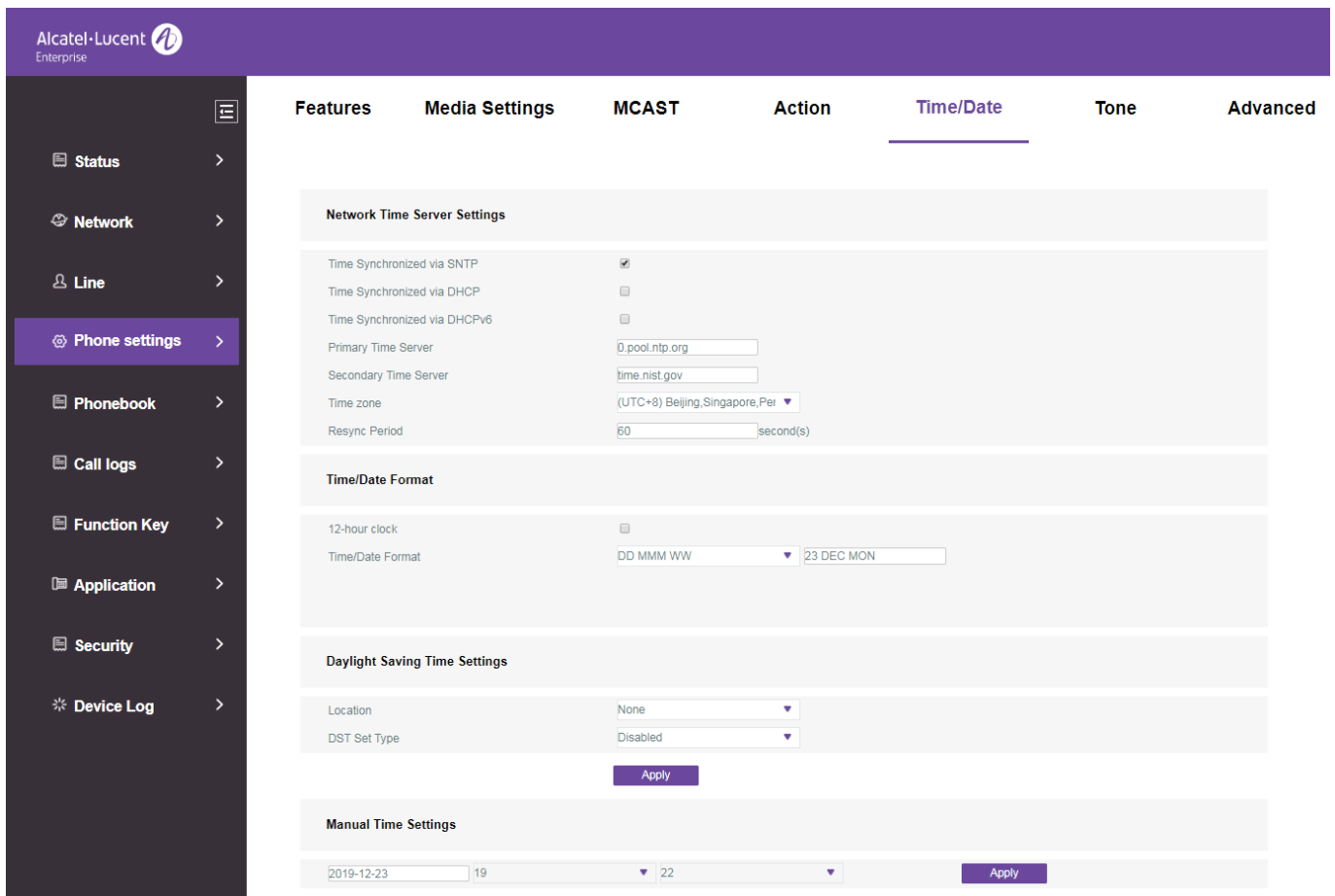

Figure 77 - Setting time & date on the web page

Table 13 - Time Settings Parameters

Parameters	Description
Mode	Auto/Manual Auto: Enable network time synchronization via SNTP protocol, default enabled. Manual: User can modify data manually.
SNTP Server	SNTP server address
Time Zone	Select the time zone
Time Format	Select time format from one of the followings: <ul style="list-style-type: none"> ■ 1 JAN, MON ■ 1 January, Monday ■ JAN 1, MON ■ January 1, Monday ■ MON, 1 JAN ■ Monday, 1 January ■ MON, JAN 1 ■ Monday, January 1

Parameters	Description
	<ul style="list-style-type: none"> ■ DD-MM-YY ■ DD-MM-YYYY ■ MM-DD-YY ■ MM-DD-YYYY ■ YY-MM-DD ■ YYYY-MM-DD
Separator	Choose the separator between year and month and day
12-Hour Clock	Display the clock in 12-hour format
Daylight Savings Time	Enable or disable Daylight Savings Time

10.1.3 Screen

The user can set the telephone screen parameters via both the telephone interface and web interface.

- Telephone: When the telephone is in the default standby status, go to [**Setting**] >> [**Phone**] >> [**Display**] to edit the screen parameters. After editing, click [**OK**] to save, as shown in the figure:

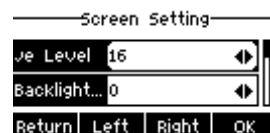

Figure 78 - Setting screen parameters on the telephone

- Web: Go to [**Phone Settings**] >> [**Advanced**], edit the screen parameters, and click Apply to save.

10.1.3.1 Brightness and backlight

- Set the brightness level from 1 to 16, [**<**] or [**>**] to change the brightness level.
- Set the brightness level in the energy-saving mode from 0 to 16, [**<**] or [**>**] to change the brightness level.
- Set the backlight time to 30 seconds by default. You can turn it off or select 15 seconds/30 seconds/45 seconds/60 seconds/90 seconds/120 seconds.
- The screen saver can be turned on or off by default.
- Web interface: Go to [**Phone Settings**] >> [**Advanced**], edit the screen parameters, and click submit to save.

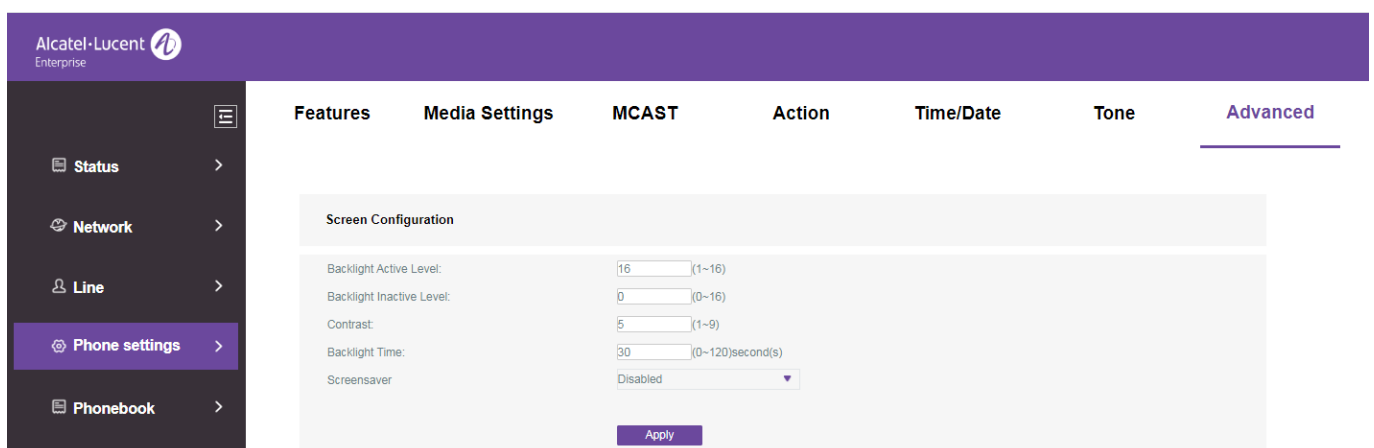

Figure 79 - Screen settings on the web

10.1.3.2 Screen saver

- Press **[Screen Settings]** to find the **[Screen protection]** button, press the **[left]/[right]** button to open/close the screen protection, and set the timeout time. The default is 15 seconds. After completion, press the **[OK]** button to save.
- After saving, return to standby mode and enter the screen saver after 15 seconds, as follows:



Figure 80 - Telephone screen saver

10.1.4 Ring

When the device is in the default standby mode,

- Press **[Setting]** >> **[Phone]** >> **[Ringling]**.
- Press the left/right navigator keys to adjust the ring volume of **[Headset]** or **[Handsfree]**.
- Press the left/right navigator keys to adjust **[Ring type]**.
- Save the adjustment by pressing **[OK]**.

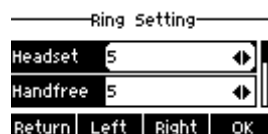

Figure 81 - Setting the telephone ring

- You can also press key  or  to adjust the ring volume.

10.1.5 Voice volume

When the device is in a call,

- Press the  or  key to adjust the voice volume.



Figure 82 - Setting the voice volume

10.1.6 Greeting words

Web interface:

- Go to **[Phone Settings]** >> **[Advanced]**, edit **[Greeting Words]**, and press **[Apply]** to save.
- Go to **[Phone Settings]** >> **[Features]** >> **[Basic Settings]**, uncheck **[Enable Default Line]**, and press **[Apply]** to save.

NOTE: The welcome message can only be displayed in the upper left corner in standby mode when the **Enable Default Line** option is disabled.

10.1.7 Reboot

When the device is in the default standby mode,

- Press **[Setting]** >> **[Reboot]**.
- Press **[OK]**. A prompt message “Reboot Now?” prompts the user.
- Press **[OK]** to reboot the telephone. A prompt message “Rebooting...” prompts the user.
- The telephone restarts.

10.2 Phonebook

10.2.1 Local contacts

The user can save contacts’ information in the phonebook and dial the contact’s telephone number(s) from the phonebook. To open the phonebook, the user should press the soft-menu button **[more]** then **[Dir]** in the default standby screen or keypad.

By default, the phonebook is empty. The user may add contact(s) to the phonebook manually or from call logs.



Figure 83 - Phonebook screen



Figure 84 - Local phonebook

When there are contact records in the phonebook, the contact records will be arranged in alphabet order. The user may browse the contacts using the up/down navigator keys. The record indicator tells the user which contact is currently focused. The user may check the contact’s information by pressing the **[OK]** button.

10.2.1.1 Add/Edit/Delete Contact

To add a new contact, the user should press the **[Add]** button to open the Add Contact screen and enter the contact information as follows;

- Name
- Office number
- Mobile
- Other number
- Line
- Ring type
- Group



Figure 85 - Adding a new contact

The user can edit a contact by pressing the **[Option]** >> **[Edit]** button.

To delete a contact, the user should move the record indicator to the position of the contact to be deleted. Press the **[Option]** >> **[Delete]** button and confirm with **[OK]**.

10.2.1.2 Add/Edit/Delete Group

By default, the group list is blank. The user can create his/her own groups, edit the group name, add or remove contacts in the group, and delete a group.

- To add a group, press the **[Add]** button.
- To delete a group, press the **[Option]** >> **[Delete]** button.
- To edit a group, press the **[Edit]** button.

The number behind the group name means the total number of contacts of selected groups.



Figure 86 - Group list

10.2.1.3 Browse and add/remove contacts in group

The user can browse contacts in a group by opening the group in the group list with the **[OK]** button.

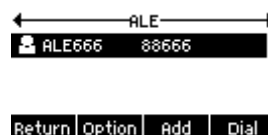

Figure 87 - Browsing contacts in a group

When the user is browsing the contacts in a group, the user can also add contacts to that group by pressing the **[Add]** button to enter the group contacts management interface, then pressing the **[OK]** button to save the contact. The contact will also be added to the local phonebook. The user can delete a contact from the group using **[Option]** >> **[Delete]**.



Figure 88 - Adding contacts to a group

10.2.2 Blacklist

The device supports a blacklist, such as numbers added to a blacklist, i.e., the telephone numbers directly refused by the near end. In this case, the near end of the telephone shows no incoming calls (blacklisted numbers can normally be called, however).

There are multiple ways to add a number to the Blacklist in the telephone.

- It can be added directly by going to **[More]** >> **[Dir]** >> **[Blacklist]**.
- Select any number in the phonebook (both local and network), press **[Option]** >> **[Add to Blacklist]**
- Select any number in the Call Log, press **[Option]** >> **[Add to Blacklist]**.



Figure 89 - Adding to the blacklist

There are various ways to add numbers to the blacklist on the web page.

- They can be added in the **[Phonebook]** >> **[Call list]** >> **[Restricted Incoming Calls]**.
- Select any number in the phonebook (both local and network) for additional configuration.
- Select any number in the Call Log for additional configuration.

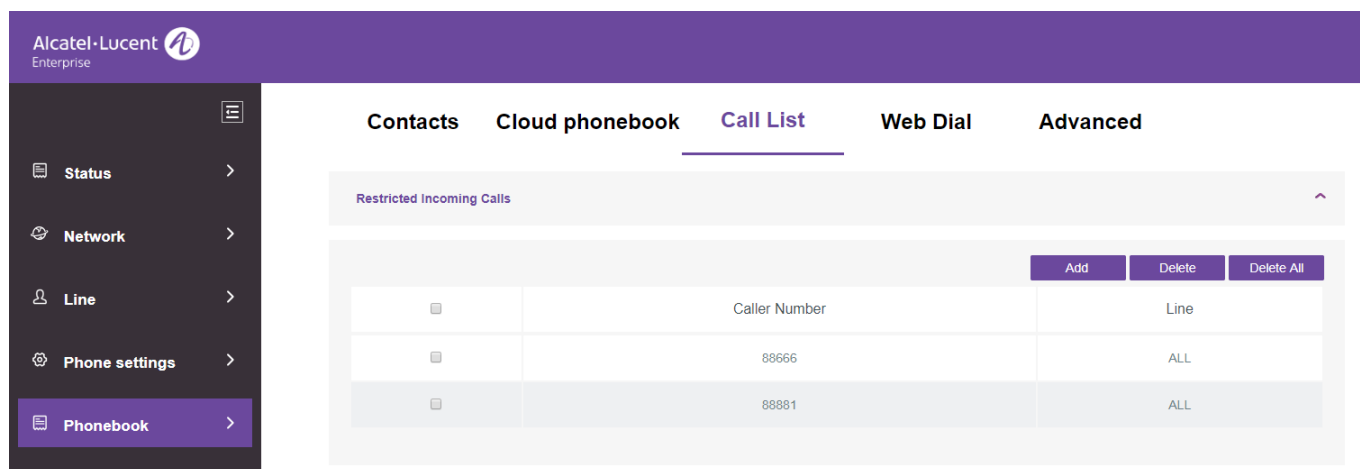

Figure 90 - Blacklist on the web page

10.2.3 Cloud phonebook

10.2.3.1 Configuring the cloud phonebook

The cloud phonebook allows the user to configure the device by downloading a phonebook from a cloud server. This is convenient for office users because they can use the phonebook from a single source and save the effort of creating and maintaining the contact list individually. It is also a useful tool for synchronizing his/her phonebook from a personal mobile telephone with the device using a Cloud Phonebook Service and App, which is to be provided publicly soon.

NOTE: *The cloud phonebook is ONLY temporarily downloaded to the device each time when it is opened on the device to ensure the user gets the latest phonebook. However, the downloading may take a couple of seconds, depending on the network condition. Therefore, it is highly recommended that users save important contacts from the cloud to their local phonebook for saving download time.*

Open cloud phonebook list, press **[More]** >> **[Dir]** >> **[Cloud Contacts]** in the phonebook screen.

TIPS: *The first configuration of the cloud phonebook should be completed on the web page by selecting **[Phonebook]** >> **[Cloud Contacts]**. Additions and deletions on the device can be done after the first setting on the web page, see [12.15 Phonebook >> Cloud phonebook](#).*



Figure 91 - Cloud phonebook list

10.2.3.2 Downloading the cloud phonebook

In the cloud phonebook screen, the user can open a cloud phonebook by pressing the **[OK]/[Enter]** button. The device will start downloading the phonebook. The user will be prompted with a warning message if the download fails,

Once the cloud phonebook is downloaded completely, the user can browse the contact list and dial the contact number in the same manner as with a local phonebook.



Figure 92 - Downloading the cloud phonebook

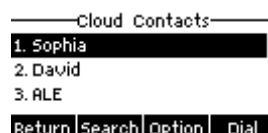

Figure 93 - Browsing contacts in the cloud phonebook

10.3 Call Log

The telephone can store the call record (the amount of storage varies according to different specifications). The user can press **[Call Log]** to open the call record and check the records of all incoming calls, outgoing calls, and missed calls.

In the Call Log interface, the user may browse the call logs using the up/down navigator keys. Each call log record is presented with 'call type', 'call party number/name' and 'call time'. The user can check further Call Log details by pressing the **[OK]** button and dialing the number with the **[Dial]** button, or by adding the Call Log number to the phonebook by pressing **[Option]** >> **[Add to Contact]**. The user can delete a call log by pressing the **[Delete]** button and clear all call logs by pressing **[Option]** > **[Delete All]**.

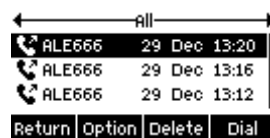

Figure 94 - Call Log

Users can also filter the call records for specific call types to narrow down the scope of search records, and also select a call record type by left and right navigation keys.

- ☎ - Missed Call Log
- ☎ - Incoming Call Log
- ☎ - Outgoing Call Log
- ☎ - Forward Call Log



Figure 95 - Filtering call record types

10.4 Function key

The user can also long press the line key. In the Dsskey interface, a function key can be configured.



Figure 96 - DSS key configuration screen

The DSS key can be configured as follows:

- ◆ Line
- ◆ Memory Key
 - Intercom/Presence/Voice Mail/Call Park/Call Forward/Speed Dial/BLF
- ◆ Key Event
 - MWI/DND/Hold/Transfer/Phonebook/Redial/Pickup/Call Forward (to specified line)/Headset/Release
- ◆ DTMF
- ◆ Action URL

- ◆ BLF List Key
- ◆ Multicast
- ◆ Action URL
- ◆ XML Browser

Webpage interface: **[Function key]** >> **[Function key]**.

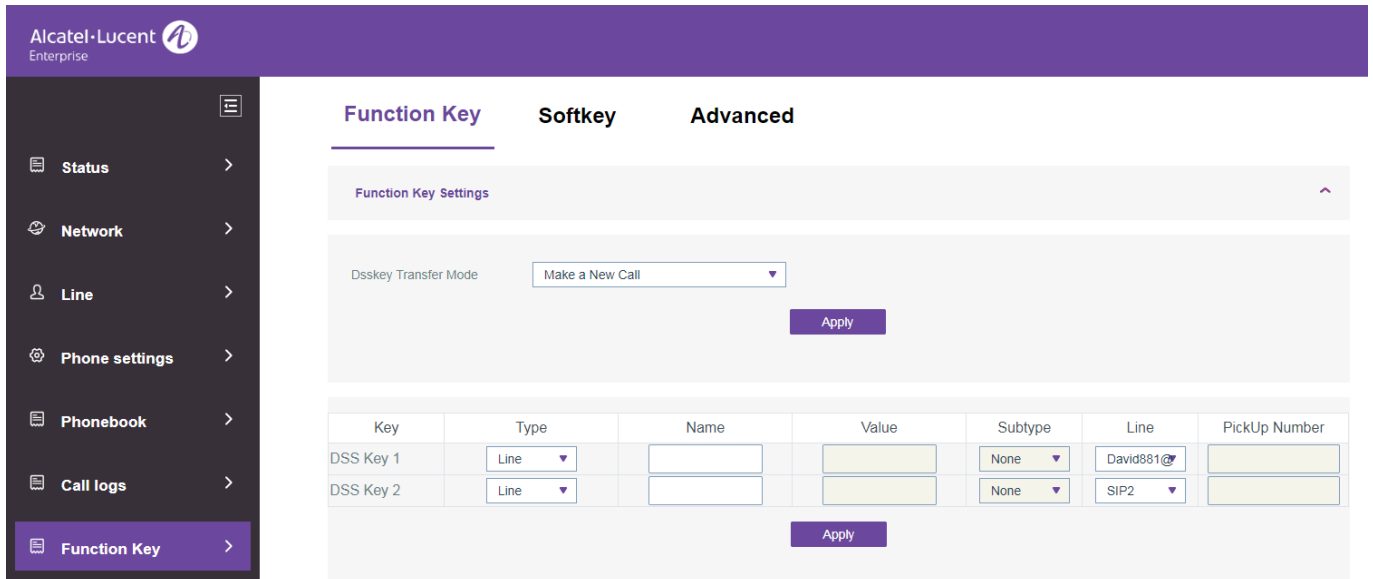

Figure 97 - DSS key settings

Moreover, the user can add the user-defined title for the DSS Keys, which is configured as Memory Key/Line/URL/Multicast/Prefix.

For more detailed information, refer to [12.20 Function Key >> Function Key](#) and [6.3 Appendix III - LED Definition](#).

10.5 Headset

10.5.1 Wired headset

- The device supports a wired earphone with RJ9 interface which can play incoming call sound and talking with earphones.
- If a DSS key is set as the headset key: When the telephone is connected to the headset, the blue LED of the headset key will be turned on, indicating that the headset can be used normally.
- On the web page **[Phone settings]** >> **[Features]**, you can set the headset answering function, and the ring from headset or not.

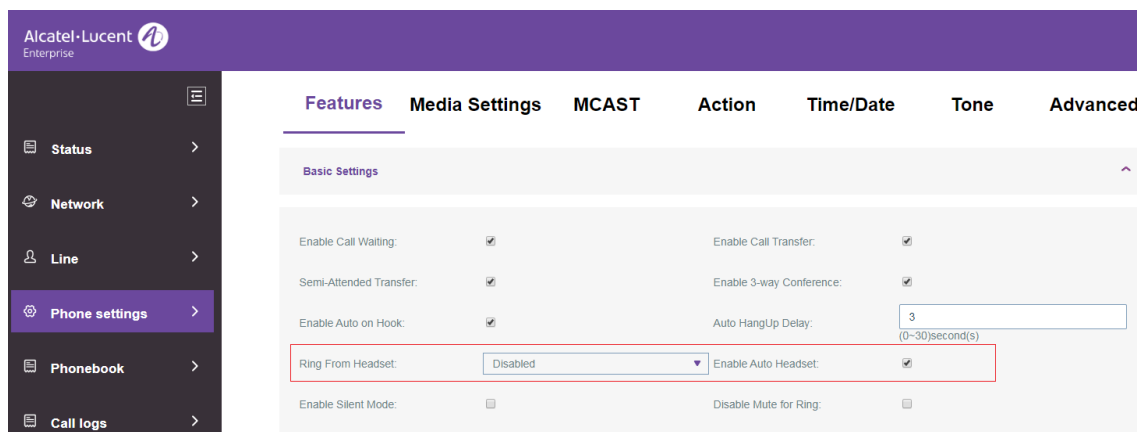

Figure 98 - Headset function settings

10.6 Advanced

10.6.1 Line configurations

In [7.7 SIP configurations](#), the basic SIP configuration has been set.

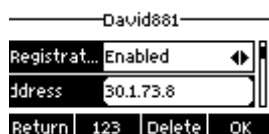

Figure 99 - SIP address and account information

Users who want to configure more options can go to the web interface to make modifications, or to Advanced Settings in the SIP accounts on the individual line to configure those options.

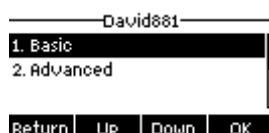

Figure 100 - Configuring advanced line options

10.6.2 Network settings

10.6.2.1 Network settings

■ IP mode

There are 3 network protocol mode options, IPv4, IPv6 and IPv4 & IPv6.

The user can select available modes via “<” or “>”. The selected IP mode will be activated after pressing the [OK] button.

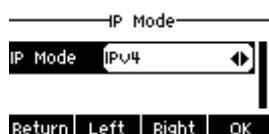

Figure 101 - Network mode settings

■ IPv4

In IPv4 mode, there are 3 connection mode options: DHCP, PPPoE and Static IP.

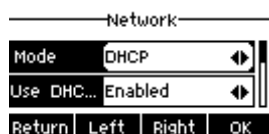

Figure 102 - DHCP network mode

When using DHCP mode, the telephone will get the IP address from the DHCP server (router).

- Using DHCP DNS: This is enabled as the default. “Enable” means the telephone will get a DNS address from the DHCP server, and “disable” means it will not.
- Using DHCP time: This is disabled as the default. “Enable” means the time for getting the DNS address from the DHCP server is managed, and “disable” means it is not.

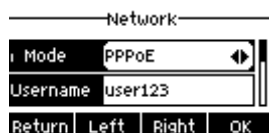

Figure 103 - PPPoE network mode

When using PPPoE, the telephone will get the IP address from the PPPoE server.

- Username: PPPoE username.
- Password: PPPoE password.

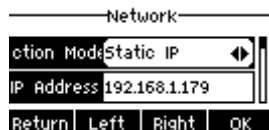

Figure 104 - Static IP network mode

When using Static IP mode, the user must configure the IP address manually.

- IP address: telephone IP address.
- Mask: sub mask of your LAN.
- Gateway: the gateway IP address. The telephone can access the other network via this address.
- Primary DNS: Primary DNS address. The default is 8.8.8.8, Google DNS server address.
- Secondary DNS: When the primary DNS is not available, the secondary DNS will work.

■ IPv6

In IPv6, there are 2 connection mode options, DHCP and Static IP.

- The DHCP configuration refers to the IPv4 introduction on the last page.
- A static IP configuration is almost the same as the one for IPv4, except for the IPv6 prefix.
- IPv6 Prefix: IPv6 prefix, it is similar with mask of IPv4.



Figure 105 - IPv6 static IP network mode

10.6.2.2 QoS & VLAN

On the webpage, go to **[Network]** >> **[Advance]**. Here, you can configure:

■ LLDP

Link Layer Discovery Protocol. LLDP is a vendor-independent link layer protocol used by network devices for advertising their identity and capabilities to neighbors on a LAN segment.

The telephone can use LLDP to find the VLAN switch or other VLAN devices and use the LLDP learning feature to apply the VLAN ID from the VLAN switch to the telephone itself.

■ CDP

Cisco Discovery Protocol. CDP is a not-for-profit charity that runs the global disclosure system for investors, companies, cities, states and regions to manage their environmental impacts. According to CDP, Cisco devices could share OS version, IP address, hardware version and so on.

Table 14 - QoS & VLAN

Parameters	Description
LLDP setting	
Report	Enable LLDP
Interval	LLDP requests interval time
Learning	Apply the learned VLAN ID to the telephone configuration
QoS	
QoS Mode	Configure SIP DSCP and audio DSCP
WAN VLAN	
WAN VLAN	WAN port VLAN configuration
LAN VLAN	
LAN VLAN	LAN port VLAN configuration
CDP	
CDP	CDP enable/disable, CDP interval time

10.6.2.3 VPN

A Virtual Private Network (VPN) is a technology that allows a device to create a tunneling connection to a server and becomes part of the server's network. The network transmission of the device may be routed through the VPN server.

For some users, especially business users, a VPN connection might have to be established before activating a line registration. The device supports two VPN modes, Layer 2 Transportation Protocol (L2TP) and OpenVPN.

The VPN connection must be configured and started (or stopped) from the device web portal.

■ L2TP

NOTE: The device only supports non-encrypted basic authentication and non-encrypted data tunneling. For users who need data encryption, please use OpenVPN instead.

To establish an L2TP connection, users should log in to the device web portal, open the web page and go to **[Network]** >> **[VPN]**. In VPN mode, check the “Enable VPN” option and select “L2TP”, then fill in the L2TP server address, authentication username, and authentication password in the L2TP section. Press “Apply,” and then the device will try to connect to the L2TP server.

When the VPN connection is established, the VPN IP address should be displayed in the VPN status. There may be a delay in establishing the connection. The user may need to refresh the page to update the status. Once the VPN is configured, the device will try to connect with the VPN automatically when the device boots up every time until the user disables it. Sometimes, if the VPN connection is not immediately established, the user can try to reboot the device and check if the VPN connection is established after the reboot.

■ OpenVPN

To establish an OpenVPN connection, the user should get the following authentication and configuration files from the OpenVPN hosting provider and name them as follows:

OpenVPN configuration file:	client.ovpn
CA root certification:	ca.crt
Client certification:	client.crt
Client key:	client.key

The user then uploads these files to the device via the web page by going to **[Network]** >> **[VPN]** and selecting OpenVPN Files. Then the user should check “Enable VPN” and select “OpenVPN” in VPN Mode and click “Apply” to enable the OpenVPN connection.

Like the L2TP connection, the connection will be established every time the system reboots until the user disables it manually.

10.6.2.4 Web server type

Configure the Web Server mode to be HTTP or HTTPS, and this will be activated after the reboot. Then the user can use the http/https protocol to access the telephone’s web page.

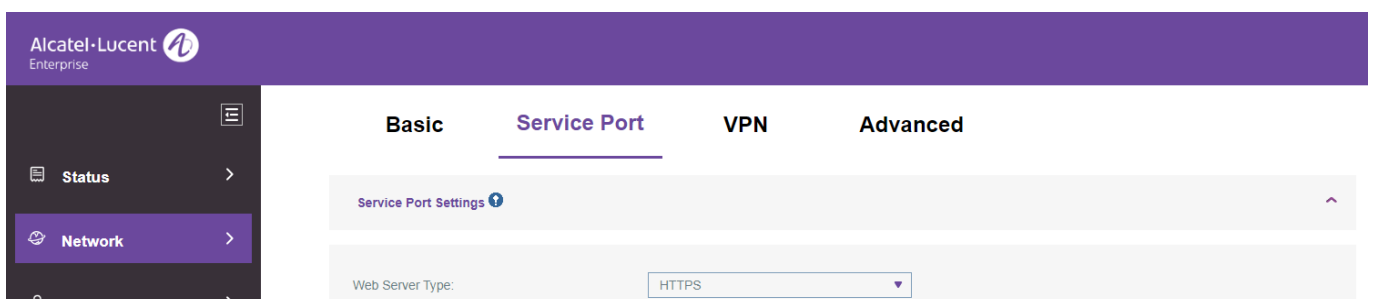

Figure 106 - Configuring the web server type

10.6.3 Set the Secret key

In the telephone, when pressing [Setting]>[Admin], the user needs to input the password.

- The default advance setting password is 123456.

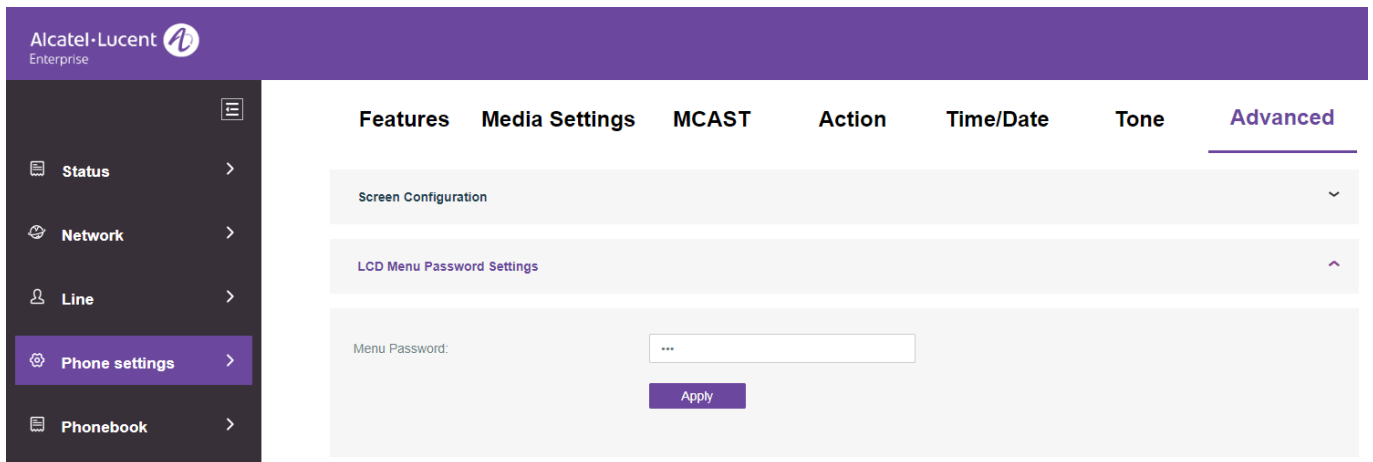

Figure 107 - Setting the admin password in the web

- The user can configure the keyboard password and lock time on the web page.

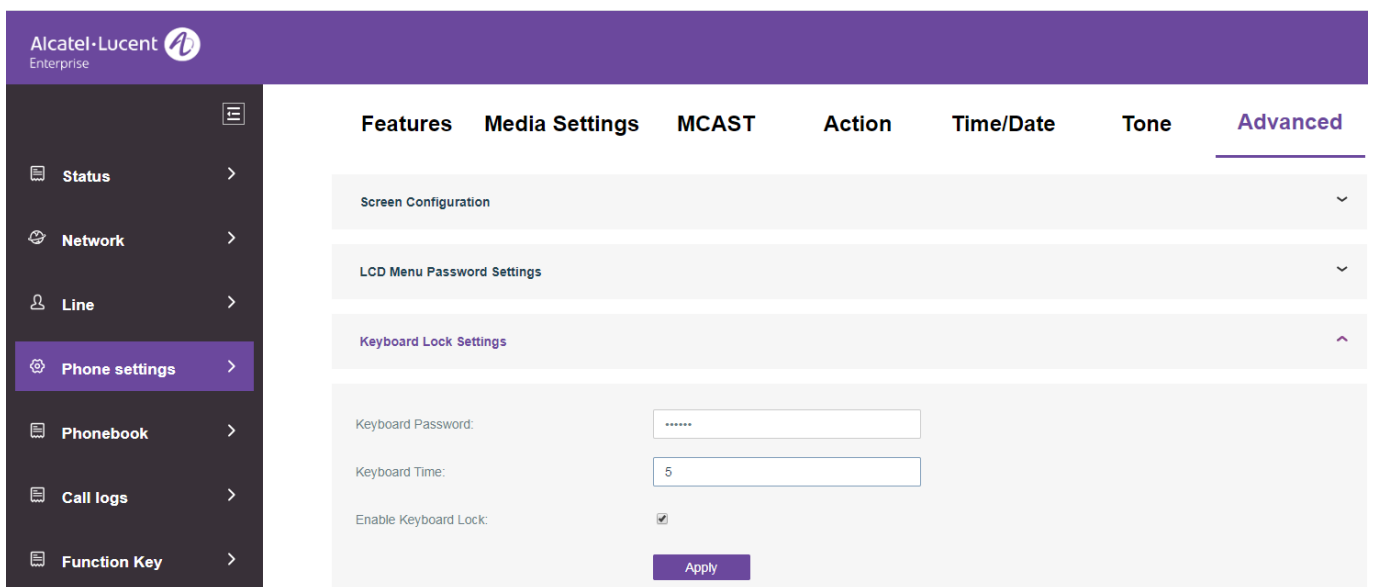

Figure 108 - Keyboard lock settings on the web

10.6.4 Maintenance

Telephone web page: Log in and go to **[Status]** >> **[Auto Provision]**.

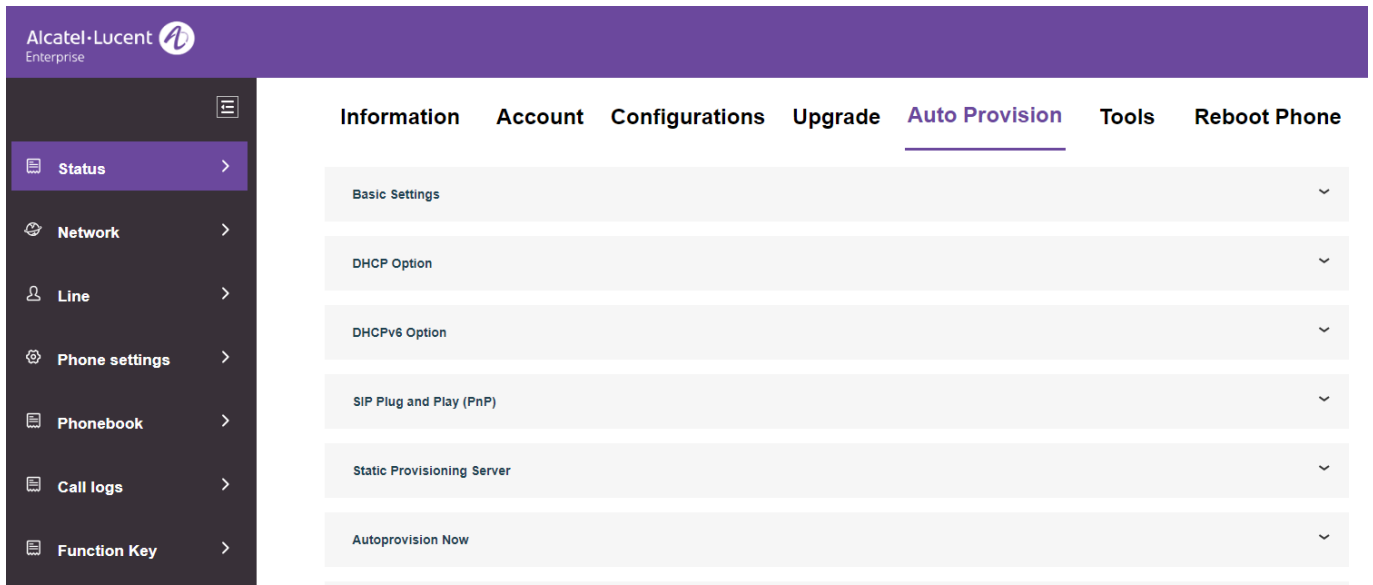

Figure 109 - Auto provision settings

The device supports SIP PnP, DHCP options, Static provision, and TR069. If all 4 methods are enabled, the priority from high to low is as follows:

PnP > DHCP > TR069 > Static Provisioning

Transfer protocol: FTP/TFTP/HTTP/HTTPS

Table 15 - Auto Provision

Parameters	Description
Basic settings	
CPE Serial Number	Display the device SN
Authentication Name	The user name of provision server
Authentication Password	The password of provision server
Configuration File Encryption Key	If the device configuration file is encrypted, the user should add the encryption key here
General Configuration File Encryption Key	If the common configuration file is encrypted, the user should add the encryption key here
Download Fail Check Times	If the download fails, the telephone will retry with the configured times.
Update Contact Interval	The telephone will update the phonebook with the configured interval time. If it is 0, the feature is disabled.
Save Auto Provision Information	Save the HTTP/HTTPS/FTP user name and password. If the provision URL is kept, the information will be kept.
Download Common Config enabled	Whether the telephone will download the common configuration file.

Parameters	Description
Enable Server Digest	When this feature is enable, if the configuration of the server is changed, the telephone will download and update.
DHCP Option	
Option Value	Configuring the DHCP option: The DHCP option supports the DHCP custom option DHCP option 66 DHCP option 43, i.e., 3 methods to get the provision URL. The default is Option 66.
Custom Option Value	A Custom option value from 128 to 254 is allowed. The option value must be the same as the one defined by the server.
Enable DHCP Option 120	Use Option 120 to get the SIP server address from the DHCP server.
SIP Plug and Play (PnP)	
Enable SIP PnP	Whether PnP is enabled or not. If PnP is enabled, the telephone will send a SIP SUBSCRIBE message by broadcast method. Any server that can support the feature will respond and send a notification with URL to the telephone. This enables the telephone to get the configuration file with the URL.
Server Address	Broadcast address. Default is 224.0.0.0.
Server Port	PnP port
Transport Protocol	PnP protocol, TCP or UDP.
Update Interval	PnP message interval.
Static Provisioning Server	
Server Address	Provisioning server address. Supports both IP address and domain address.
Configuration File Name	The configuration file name. If it is empty, the elephone will request the common file and device file which is named as its MAC address. The file name could be a common name such as \$mac.cfg, \$input.cfg. The file format supports CFG/TXT/XML.
Protocol Type	Transfer protocol type: supports FTP, TFTP, HTTP and HTTPS
Update Interval	Configuration file update interval time. The default is 1. This means that the telephone will check the update every 1 hour.
Update Mode	Provision Mode. 1. Disabled. 2. Update after reboot. 3. Update after interval.
TR069	
Enable TR069	Enable TR069 after selection.
ACS Server Type	There are 2 server type options, common and CTC.
ACS Server URL	ACS server address
ACS User	ACS server username (up to 59 characters)

Parameters	Description
ACS Password	ACS server password (up to 59 characters)
Enable TR069 Warning Tone	If TR069 is enabled, there will be a prompt tone when connecting.
TLS Version	TLS version (TLS 1.0, TLS 1.1, TLS 1.2)
INFORM Sending Period	INFORM signal interval time, which ranges from 1 second to 999 seconds.
STUN Server Address	Configure STUN server address
STUN Enable	To enable STUN server for TR069

10.6.5 Firmware upgrade

- Web page: Log in to the telephone web page, go to **[Status]** >> **[Upgrade]**.

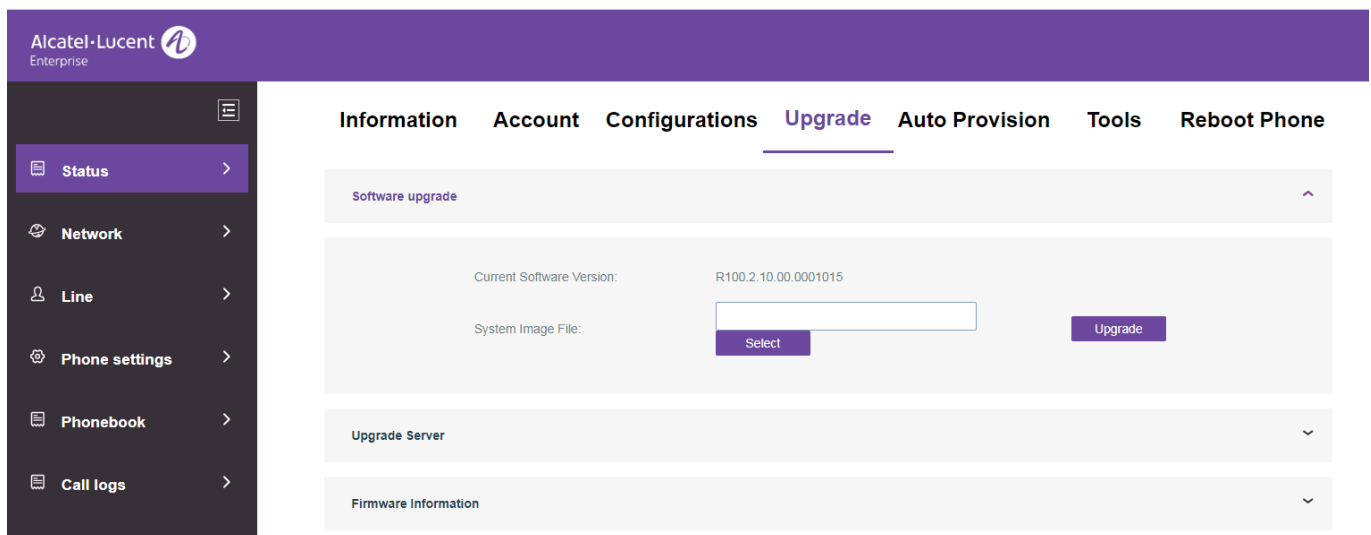

Figure 110 - Web page firmware upgrade

Table 16 - Firmware Upgrade

Parameters	Description
Upgrade server	
Enable Auto Upgrade	Enables automatic upgrade. If there is a new version txt and new software or firmware on the server, the telephone will show a prompt upgrade message after the update interval.
Upgrade Server Address1	Set available upgrade server address.
Upgrade Server Address2	Set available upgrade server address.
Update Interval	Set update interval.
Firmware Information	
Current Software Version	This will show the current software version.
Server Firmware Version	This will show the server firmware version.

Parameters	Description
[Upgrade] button	If there is a new version txt and new software or firmware on the server, the page will display the version information, and the upgrade button will become available. Click the [Upgrade] button to upgrade to the new firmware.
New version description information	When there is a corresponding TXT file and version on the server side, the TXT and version information will be displayed under the new version description information.

- The file requested from the server is a TXT file called vendor_model_hw1_0.txt.Hw followed by the hardware version number. It will be written as hw10 if there is no difference in the hardware. All spaces in the filename are replaced by underlines.
- The URL requested by the telephone is HTTP://server address/vendor_Model_hw1_0.txt. The new version and the requested file should be placed in the download directory of the HTTP server, as shown in the figure below:

名称	修改日期	类型	大小
ale_h2p_hwv1_0.txt	2020/1/13 14:50	文本文档	1 KB
H2P-5200-RECOVERY-P0.18.8-R100.2.10.0...	2020/1/13 11:12	WinRAR 压缩文件	10,472 KB

- TXT file format must be UTF-8
- vendor_model_hw1_0.TXT The file format is as follows:
Version= R100.2.10.00.0001020 #Software Version
Firmware=xxx/xxx.z #URL, Relative paths are supported and absolute paths are possible, distinguished by the presence of protocol headers.
BuildTime=2018.09.11 20:00
Info=TXT|XML

Xxxxx
Xxxxx
Xxxxx
Xxxxx
- After the interval of the update cycle arrives, if the server has available files and versions, the telephone will prompt as shown below. Click [view] to check the version information and upgrade.

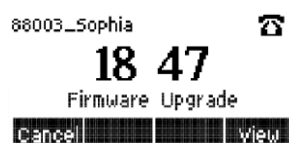

Figure 111 - Firmware upgrade

10.6.6 Factory reset

The telephone is in default standby mode.

- Press [**Setting**]>[**Admin**], and press the OK key.
- Enter the password (default password is 123456) to enter the interface.
- Select [**Restore factory**] and press the OK key. Select the file to be cleared.
- Press [**OK**] to clear after completion.

When you select “clear configuration file” or “clear all”, the telephone will restart automatically after clearing.

11 Web Configurations

11.1 Web page authentication

The user can log in to the web page of the telephone to manage the user's telephone information and operate the telephone. Users must provide the correct user name and password to log in.

11.2 Status >> Information

The user can get the system information of the device in this page including,

- Model
- Hardware Version
- Software Version
- Uptime

And a summary of the network status:

- Network Mode
- MAC Address
- IP
- Subnet Mask
- Default Gateway

As well as a summary of the SIP account status

- SIP User
- SIP account status (Registered/Inactive/Trying/Timeout)

11.3 Status >> Account

On this page, the user can change the password for the login page.

Users with administrator rights can also add or delete users, manage users, and set permissions and passwords for new users.

11.4 Status >> Configurations

On this page, users with administrator privileges can view, export, or import the telephone configuration, or restore the telephone to factory settings.

■ Clear configurations

Select the module in the configuration file to clear.

SIP: account configuration.

AUTOPROVISION: automatically upgrades the configuration

TR069:TR069 related configuration

MMI: MMI module, including authentication user information, web access protocol, etc.

DSS Key: DSS key configuration

- **Clear data tables**

Select the local data table to be cleared, all selected by default.

- **Reset telephone**

The telephone data will be cleared, including configuration and database tables.

11.5 Status >> Upgrade

Upgrade the telephone software version, customized ringtone, background, DSS key icon, etc., can also be upgraded to delete the file. Ring tone support. “.wav” format.

11.6 Status >> Auto Provision

The Auto Provision settings help the IT manager or service provider to easily deploy and manage the devices in mass volume. For details on Auto Provision, please refer to this link: [Auto Provision Description](#).

11.7 Status >> Tools

Tools provided in this page help users to identify issues when troubleshooting. Please refer to [13 Troubleshooting](#) for more detail.

11.8 Status >> Reboot Telephone

This page can restart the telephone.

12 Network >> Basic

This page allows users to configure network connection types and parameters.

12.1 Network >> Service Port

This page provides settings for Web page login protocol, protocol port settings and RTP port.

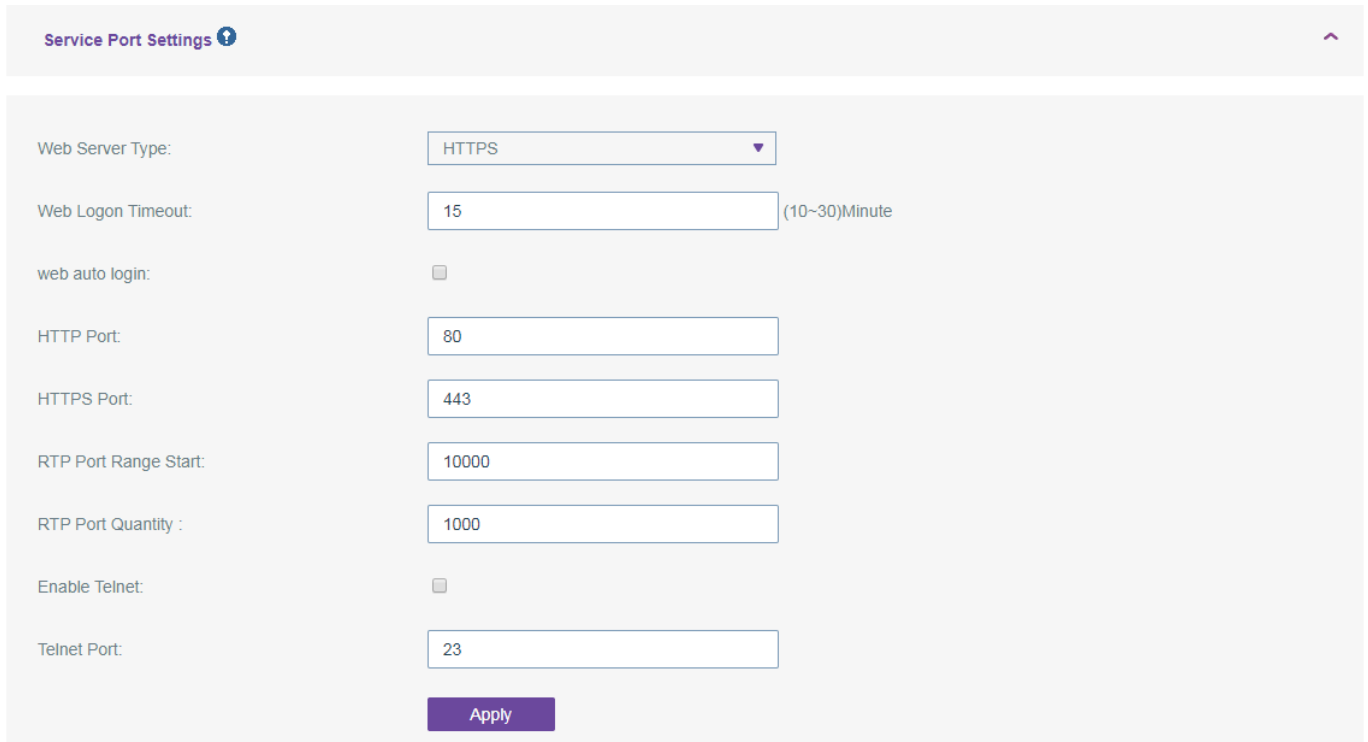

Figure 112 - Service port settings

Table 17 - Service Port

Parameters	Description
Web Server Type	Reboot to take effect after settings. Optionally, the web page login is HTTP/HTTPS.
Web Logon Timeout	Default as 15 minutes, the timeout will automatically exit the login page, need to login again.
Web auto login	After the timeout, you do not need to enter a user name and password because it will automatically login to the web page.
HTTP Port	The default is 80. If you want system security, you can set ports other than 80. Such as: 8080, webpage login: HTTP://ip:8080
HTTPS Port	The default is 443, the same as the HTTP port.
RTP Port Range Start	The value range is 1025 to 65535. The RTP port value starts from the initial value set. For each call, 2 is added to the value of the voice and video port.
RTP Port Quantity	Number of calls.

12.2 Network >> VPN

Users can configure a VPN connection on this page. See [10.6.2.3 VPN](#) for more details.

12.3 Network >> Advanced

Advanced network settings are typically configured by the IT administrator to improve the quality of the telephone service. For configuration, see [10.6 Advanced](#) Settings.

12.4 Line >> SIP

Configure the line service configuration on this page.

Table 18 - Line configuration on the web page

Parameters	Description
Register Settings	
Line Status	Display the current line status at page loading. To get an up-to-date line status, the user has to refresh the page manually.
Activate	Whether the line service is activated.
Username	Enter the username of the service account.
Authentication User	Enter the authentication user of the service account.
Display Name	Enter the display name to be sent in a call request.
Authentication Password	Enter the authentication password of the service account.
Realm	Enter the SIP domain if requested by the service provider.
Server Name	Input server name.
SIP Server 1	
Server Address	Enter the IP or FQDN address of the SIP server
Server Port	Enter the SIP server port, default is 5060
Transport Protocol	Set up the SIP transport line using TCP or UDP or TLS.
Registration Expiration	Set SIP expiration date.
SIP Server 2	
Server Address	Enter the IP or FQDN address of the SIP server
Server Port	Enter the SIP server port, default is 5060
Transport Protocol	Set up the SIP transport line using TCP or UDP or TLS.
Registration Expiration	Set SIP expiration date.
SIP Proxy Server Address	Enter the IP or FQDN address of the SIP proxy server.
Proxy Server Port	Enter the SIP proxy server port, default is 5060.
Proxy User	Enter the SIP proxy user.
Proxy Password	Enter the SIP proxy password.
Backup Proxy Server Address	Enter the IP or FQDN address of the backup proxy server.
Backup Proxy Server Port	Enter the backup proxy server port, default is 5060.

Parameters	Description
Basic Settings	
Enable Auto Answering	Enables auto-answering. Incoming calls will be answered automatically after the delay time.
Auto Answering Delay	Sets the delay for an incoming call before the system automatically answers it.
Call Forward Unconditional	Enables unconditional call forwarding. All incoming calls will be forwarded to the number specified in the next field.
Call Forward Number for Unconditional	Sets the number for unconditional call forwarding.
Call Forward on Busy	Enables call forwarding on busy when the telephone is busy. Any incoming call will be forwarded to the number specified in the next field.
Call Forward Number for Busy	Sets the number for call forwarding on busy.
Call Forward on No Answer	Enables call forwarding on no answer. When an incoming call is not answered within the configured delay time, the call will be forwarded to the number specified in the next field.
Call Forward Number for No Answer	Sets the number for call forwarding on no answer.
Call Forward Delay for No Answer	Sets the delay time for an unanswered call before being forwarded.
Transfer Timeout	Sets the timeout for the call transfer process.
Conference Type	Sets the type of call conference, Local=set up call conference by the device itself, maximum supports two remote parties, Server=set up call conference by dialing to a conference room on the server
Server Conference Number	Sets the conference room number when the conference type is set to be Server
Subscribe For Voice Message	Enables the device to subscribe to a voice message waiting notification. If enabled, the device will receive notification from the server if there is voice message waiting on the server.
Voice Message Number	Sets the number for retrieving voice messages.
Voice Message Subscribe Period	Sets the interval for voice message notification subscription.
Enable Hotline	Enables hotline configuration. The device will dial the specific number immediately if audio channel is opened by off-hook handset or hands-free speaker or headphone is turned on.
Hotline Delay	Sets the delay for hotline before the system automatically dials it.
Hotline Number	Sets the hotline dialing number.
Dial Without Registered	Sets call out by proxy without registration.

Parameters	Description
Enable Missed Call Log	If enabled, the phone will save missed calls in the call history record.
DTMF Type	Sets the DTMF type to be used for the line.
DTMF SIP INFO Mode	Sets the SIP INFO mode to send '*' and '#' or '10' and '11'.
Enable DND	Enables Do-not-disturb. Any incoming call to this line will be rejected automatically.
Subscribe For Voice Message	Enables the device to subscribe to a voice message waiting notification. If enabled, the device will receive notification from the server if there is a voice message waiting on the server.
Use VPN	Sets the line to use VPN restricted route.
Use STUN	Sets the line to use STUN for NAT traversal.
Enable Failback	Whether or not to switch to the primary server when it is available.
Failback Interval	A Register message is used to periodically detect the time interval for the availability of the main Proxy.
Signal Failback	Multiple proxy cases, whether to allow the invite/register request to also execute failback.
Signal Retry Counts	The number of attempts that the SIP Request considers proxy unavailable under multiple proxy scenarios.
Codecs Settings	Sets the priority and availability of the codecs by adding or remove them from the list.
Video Codecs	Selects video code to preview video.
Advanced Settings	
Use Feature Code	When this setting is enabled, the features in this section will not be handled by the device itself but by the server instead. In order to control the enabling of the features, the device will send feature code to the server by dialing the number specified in each feature code field.
Enable DND	Set the feature code to dial to the server.
Disable DND	Set the feature code to dial to the server.
Enable Call Forward Unconditional	Set the feature code to dial to the server.
Disable Call Forward Unconditional	Sets the feature code to dial to the server.
Enable Call Forward on Busy	Sets the feature code to dial to the server.
Disable Call Forward on Busy	Sets the feature code to dial to the server.
Enable Call Forward on No Answer	Sets the feature code to dial to the server.
Disable Call Forward on No Answer	Sets the feature code to dial to the server.

Parameters	Description
Enable Blocking Anonymous Call	Sets the feature code to dial to the server.
Disable Blocking Anonymous Call	Sets the feature code to dial to the server.
Call Waiting On Code	Sets the feature code to dial to the server.
Call Waiting Off Code	Sets the feature code to dial to the server.
Send Anonymous On Code	Sets the feature code to dial to the server.
Send Anonymous Off Code	Sets the feature code to dial to the server.
SIP Encryption	Enables SIP encryption so that SIP transmission will be encrypted.
RTP Encryption	Enables RTP encryption so that RTP transmission will be encrypted.
Enable Session Timer	Sets the line to enable call ending by session timer refreshment. The call session will be ended if there is not a new session timer event update received after the timeout period.
Session Timeout	Set the session timer timeout period.
Enable BLF List	Enable/Disable BLF List
BLF List Number	BLF List allows one BLF key to monitor the status of a group. Multiple BLF lists are supported.
Response Single Codec	If setting enabled, the device will use single codec in response to an incoming call request.
BLF Server	The registered server will receive the subscription package from the ordinary application of a BLF telephone. Please enter the BLF server if the sever does not support a subscription package. The registered server and subscription server will be separated.
Keep Alive Type	Sets the line to use dummy UDP or SIP OPTION packet to keep NAT pinhole opened.
Keep Alive Interval	Sets the "keep alive" packet transmitting interval
Keep Authentication	Keeps the authentication parameters from previous authentication.
Blocking Anonymous Call	Rejects any incoming call that does not present a caller ID.
User Agent	Sets the user agent. The default is Model with Software Version.
Specific Server Type	Sets the line to collaborate with specific server type.
SIP Version	Sets the SIP version.
Anonymous Call Standard	Sets the standard to be used for anonymous.
Local Port	Sets the local port.
Ring Type	Sets the ring tone type for the line.
Enable user=phone	Sets user=phone in SIP messages.
Use Tel Call	Sets use tel call.

Parameters	Description
Auto TCP	Uses TCP protocol to guarantee usability of transport for SIP messages above 1500 bytes.
Enable Rport	Sets the line to add rport in SIP headers.
Enable PRACK	Sets the line to support PRACK SIP message.
DNS Mode	Selects DNS mode, A, SRV, NAPTR.
Enable Long Contact	Allows more parameters in contact field per RFC 3840.
Enable Strict Proxy	Enables the use of strict routing. When the telephone receives packets from the server, it will use the source IP address, not the address in via field.
Convert URI	Converts non-digits and alphabet characters to %hh hex code
Use Quote in Display Name	Whether to add quote in display name.
Enable GRUU	Supports Globally Routable User-Agent URI (GRUU).
Sync Clock Time	Time Sync with server.
Enable Inactive Hold	With the post-call hold capture package enabled, you can see that in the INVITE package, SDP is inactive.
Caller ID Header	Sets the caller ID header.
Use 182 Response for Call waiting	Sets the device to use 182 response code at call waiting response.
Enable Feature Sync	Feature Sync with server.
Enable SCA	Enables/disables SCA (Shared Call Appearance)
CallPark Number	Sets the CallPark number.
Server Expire	Sets the timeout to use the server.
TLS Version	Chooses TLS Version.
uaCSTA Number	Sets uaCSTA number.
Enable Click To Talk	With the use of a special server, click to call out directly after enabling.
Flash mode	Chose flash mode, normal or SIP info.
Flash Info Content-Type	Sets the SIP info content type.
Flash Info Content-Body	Sets the SIP info content body.
PickUp Number	Sets the scramble number when Pickup is enabled.
JoinCall Number	Sets JoinCall number.
Intercom Number	Sets Intercom number.
Unregister On Boot	Whether to enable logout function.
Enable MAC Header	When opening the registration, IP package and user agent with MAC.
Enable Register MAC Header	When opening the registration, user agent with MAC.
BLF Dialog Strict Match	Whether to enable accurate matching of BLF sessions.

Parameters	Description
PTime(ms)	Sets whether to bring ptime field, default no.
SIP Global Settings	
Strict Branch	Sets up to strictly match the Branch field.
Enable Group	Sets open group.
Enable RFC4475	Sets to enable RFC4475.
Enable Strict UA Match	Enables strict UA matching.
Registration Failure Retry Time	Sets the registration failure retry time.
Local SIP Port	Modifies the telephone SIP port.

12.5 Line >> Dial Plan

Basic Settings ^

Press # to invoke dialing

Dial Fixed Length to Send

Send after second(s)(3-30)

Press # to Do Blind Transfer

Blind Transfer on Onhook

Attended Transfer on Onhook

Attended Transfer on Conference Onhook

Enable E.164

Figure 113 - Dial plan settings

Table 19 - Telephone Dialing Methods

Parameters	Description
Press # to start dialing	The user dials the other party's number and then adds the # number to dial out;
Dial Fixed Length	The number entered by the user is automatically dialed out when it reaches a fixed length.
Timeout dial	The system dials automatically after timeout.
Press # to Do Blind Transfer	The user enters the number to be transferred and then presses the “#” key to transfer the current call to a third party.
Blind Transfer on Onhook	After the user enters the number, hang up the handle or turn off the hands-free function to transfer the current call to a third party.
Attended Transfer on Onhook	Hang up the handset or press the hands-free button to perform an attended transfer, which can transfer the current call to a third party.
Attended Transfer on Conference Onhook	During a three-way call, hang up the handset, and the remaining two parties remain on the call.
Enable E.164	Please refer to E. 164 standard specification

Add dialing rules:

Dial Plan Add
^

Digit Map:

Apply to Call: Match to Send:

Line: Destination: Port:

Alias(Optional): Phone Number: Length:

Suffix:

Dial Plan Option
v

User-defined Dial Plan Table
v

Figure 114 - Custom setting of dial-up rules

Table 20 - Dial-up Rule Configuration Table

Parameters	Description
Dial rule	There are two types of matching: full matching or prefix matching. In full matching, the entire telephone number is entered and then mapped per the Dial Peer rules. In prefix matching, only part of the number is entered, followed by T. The mapping then takes place whenever these digits are dialed. Prefix mode supports a maximum of 30 digits.
<p>Note: Two different special characters are used.</p> <ul style="list-style-type: none"> ■ x -- matches any single digit that is dialed. ■ [] -- specifies a range of numbers to be matched. It may be a range, a list of ranges separated by commas, or a list of digits. 	
Destination	Sets destination address. This is for IP direct.
Port	Sets the signal port, and the default is 5060 for SIP.
Alias	Sets the alias. This is the text to be added, replaced or deleted. This is an optional item.
<p>Note: There are four types of aliases.</p> <ul style="list-style-type: none"> ■ all: xxx - xxx will replace the telephone number. ■ add: xxx - xxx will be dialed before any telephone number. ■ del -The characters will be deleted from the telephone number. ■ rep: xxx - xxx will be substituted for the specified characters. 	

Parameters	Description
Suffix	Characters to be added at the end of the telephone number. This is an optional item.
Length	Set the number of characters to be deleted. For example, if this is set to 3, the telephone will delete the first 3 digits of the telephone number. This is an optional item.

This feature allows the user to create rules to make dialing easier. There are several different options for dial rules. The examples below will show how this can be used.

Example 1: All Substitution -- Assumes that a direct IP call can be made to IP address 135.251.222.169. Using this feature, 169 can be substituted for 135.251.222.169.

User-defined Dial Plan Table						
Index	Digit Map	Call	Match to Send	Line	Alias Type: Number(length)	Suffix
1	"169"	Out	No	SIP DIALPEER(135.251.222.169:5060)		

Figure 115 - Dial rules table (1)

Example 2: Partial Substitution -- Dialing a long distance call to Beijing requires dialing area code 010 before the local telephone number. Using this feature, 1 can be substituted for 010. For example, to call 62213123 would only require dialing 162213123 instead of 01062213123.

User-defined Dial Plan Table						
Index	Digit Map	Call	Match to Send	Line	Alias Type: Number(length)	Suffix
1	"1T"	Out	No	88881_David@SIP1	rep:010(1)	

Figure 116 - Dialing rules table (2)

Example 3: Addition -- Two examples are shown. In the first case, it is assumed that 0 must be dialed before any 11-digit number beginning with 13. In the second case, it is assumed that 0 must be dialed before any 11-digit number beginning with 135, 136, 137, 138, or 139. Two different special characters are used.

x -- Matches any single digit that is dialed.

[] -- Specifies a range of numbers to be matched. It may be a range, a list of ranges separated by commas, or a list of digits.

Digit Map: "131xxxxxxx"

Apply to Call: Match to Send:

Line: Destination: Port:

Alias(Optional): Number: Length:

Suffix:

Figure 117 - Dialing rules table (3)

Digit Map: "13[5-9]xxxxxxx"

Apply to Call: Match to Send:

Line: Destination: Port:

Alias(Optional): Number: Length:

Suffix:

Figure 118 - Dialing rules table (4)

12.6 Line >> Basic Settings

Set up the register global configuration.

Table 21 - Set the line global configuration on the web page

Parameters	Description
STUN Settings	
Server Address	Sets the STUN server address.
Server Port	Sets the STUN server port, default is 3478.
Binding Period	Sets the STUN binding period which can be used to keep the NAT pinhole open.
SIP Waiting Time	Sets the timeout of STUN binding before sending SIP messages.
The TLS authentication	
TLS Certification File	Uploads or deletes the TLS certification file used for encrypted SIP transmission.

12.7 Telephone settings >> Features

Configuration of telephone features.

Table 22 - General Function Settings

Parameters	Description
Basic Settings	
Enable Call Waiting	Enables this setting to allow user to take a second incoming call during an established call. Default enabled.
Enable Call Transfer	Enables call transfer.
Semi-Attended Transfer	Enables semi-attended transfer when selected.
Enable 3-Way Conference	Enables 3-way conference when selected.
Enable Auto Onhook	The telephone will hang up and return to idle automatically in hands-free mode.
Auto HangUp Delay	Specifies Auto Onhook time. The telephone will hang up and return to idle automatically after Auto Hand down time in hands-free mode, and play dial tone Auto Onhook time in handset mode.
Ring From Headset	Enables Ring from Handset when selected. The telephone plays the ring tone from the handset.
Enable Auto Headset	To enable this feature, the headset is plugged into the telephone, the user presses the 'answer' key or line key to answer a call with the headset automatically.
Enable Silent Mode	When enabled, the telephone is muted and there is no ringing when calls come in. You can use the volume keys and mute key to unmute.
Disable Mute for Ring	When this is enabled, you cannot mute the telephone.
Enable Default Line	If enabled, the user can assign a default SIP line for dialing out rather than SIP1.
Enable Auto Switch Line	Enables the telephone to select an available SIP line as default automatically.
Default Ext Line	Selects the default line to use for outgoing calls.
Ban Outgoing	If you select Ban Outgoing to enable it, and you cannot dial out any number.
Hide DTMF	Configures the hide DTMF mode.
Enable Call Log	Selects whether to save the Call Log.
Enable Restricted Incoming List	Selects whether to enable restricted call list.
Enable Allowed Incoming List	Selects whether to enable the allowed call list.
Enable Restricted Outgoing List	Selects whether to enable the restricted allocation list.

Parameters	Description
Enable Country Code	Selects whether the country code is enabled.
Country Code	Fills in the country code.
Area Code	Fills in the area code.
Enable Number Privacy	Selects whether to enable number privacy.
Match Direction	Matches direction. There are two kinds of rules, from right to left and from left to right.
Start Position	Opens number privacy after the start of the hidden location.
Hide Digits	Turns on number privacy to hide the number of digits.
Allow IP Call	If enabled, the user can dial out with the IP address
P2P IP Prefix	Prefix a point-to-point IP call.
Caller Name Priority	Changes caller ID display priority.
Emergency Call Number	Configures the Emergency Call Number. Even if the keyboard is locked, you can dial the emergency call number.
Search path	Selects the search path.
LDAP Search	Selects with one LDAP for search.
Caller Display Type	Selects whether to display name or number.
Restrict Active URI Source IP	Sets the device to accept Active URI command from specific IP address.
Push XML Server	Configures the Push XML Server. When the telephone receives a request, it will determine whether to display corresponding content on the telephone which is sent by the specified server or not.
Enable Pre-Dial	Disables the feature in which the audio channel is automatically opened when the user enters a number. When the feature is enabled, the user can enter the number without opening the audio channel.
Enable Multi Line	If enabled, up to 10 simultaneous calls can exist on the telephone, and if disabled, up to 2 simultaneous calls can exist on the telephone.
Line Display Format	Custom line format: SIPn/SIPn: xxx/xxx@SIPn
Contact As White List Type	NONE/BOTH/DND White List/FWD White List
Block XML When Call	Disables XML push on call.
SIP notify	When enabled, the telephone displays the information when it receives the relevant content notification.
Tone Settings	
Enable Holding Tone	When turned on, a tone plays when the call is held.
Enable Call Waiting Tone	When turned on, a tone plays when the call is waiting.
Play Dialing DTMF Tone	Plays DTMF tone on the device when the user presses telephone digits when dialing. Default is enabled.

Parameters	Description
Play Talking DTMF Tone	Plays DTMF tone on the device when user presses telephone digits during taking. Default is enabled.
DND Settings	
DND Option	Selects whether DND is to take effect on the line or on the telephone or not.
Enable DND Timer	Enables DND Timer. If enabled, DND is automatically turned on from the start time to the off time.
DND Start Time	Sets DND Start Time
DND End Time	Sets DND End Time
Intercom Settings	
Enable Intercom	When intercom is enabled, the device will accept the incoming call request with a SIP header of Alert-Info instruction to automatically answer the call after a specific delay.
Enable Intercom Mute	Enables Mute mode during the intercom call.
Enable Intercom Tone	If the incoming call is an intercom call, the telephone plays the intercom tone.
Enable Intercom Barge	Enables Intercom Barge. When this is selected,, the telephone auto answers the intercom call during a call. If the current call is an intercom call, the telephone will reject the second intercom call.
Response Code Settings	
DND Response Code	Sets the SIP response code on call rejection during DND.
Busy Response Code	Sets the SIP response code when the line is busy.
Reject Response Code	Sets the SIP response code on call rejection.
Password Dial Settings	
Enable Password Dial	Enables Password Dial. When this is selected, if the number entered begins with the password prefix, the following N numbers after the password prefix will be hidden as *, N standing for the value which you enter in the Password Length field. For example, if you set the password prefix to 3 and enter the password length as 2, when you enter the number 34567, it will display as 3**67 on the telephone.
Encryption Number Length	Configures the encryption number length.
Password Dial Prefix	Configures the prefix of the password call number.
Power LED	
Common	Standby power lamp status.. Off is LED off. Open is always bright red. Off by default.
MWI	The status of the power lamp when there is an unread short message/ voice message, including off/on/slow flash/quick flash. Default is slow flash.

Parameters	Description
Missed call	The status of the power lamp when there is a missed call, including off/on/slow flash/quick flash. Default is slow flash.
Talk/Dial	In Talk/Dial status, for the power lamp status, off is off, on is always bright red. Default is off.
Ringing	Power lamp status when there is an incoming call, including off/on/slow flash/quick flash. Default is flash.
Mute	Power lamp status in Mute mode, including off/on/slow flash/quick flash, off by default.
Hold/Held	The power lamp status, including off/on/slow flash/quick flash, is turned off by default when left/retained.
Notification Popups	
Display Missed Call Popup	No incoming call popup prompt after opening, no popup prompt when closing, open by default.
Display MWI Popup	Voice message popup prompt is not answered after opening, and it is opened by default if there is no popup prompt when closing.
Display Other Popup	When the handle is not hung back up after opening, registration fails, IP acquisition fails, Tr069 connection fails, and there are other abnormalities. There will be a popup prompt when it is opened; otherwise, there will be no prompt when it is closed, and it will be opened by default.

12.8 Telephone settings >> Media settings

Change voice settings.

Table 23 - Voice Settings

Parameters	Description
Codecs Settings	Select enable or disable voice encoding: G.711A/U, G.722, G.729, G.726-16, G726-24, G726-32, G.726-40, ILBC, Opus
Audio Settings	
Handset Volume	Set the handset volume. The value must be 1~9
Default Ring Type	Configures default ring tones. If no special ring tone is set for the telephone number, the default ring tone will be used.
Speakerphone Volume	Sets the hands-free volume to 1-9.
Headset Ring Volume	Sets the volume of the earphone ring tone to 1~9.
Headset Volume	Sets the volume of the headset to 1~9.
Speakerphone Ring Volume	Sets the volume of hands-free ring tone to 1~9.
G.723.1 Bit Rate	5.3kb/s or 6.3kb/s is available.
DTMF Payload Type	Enters the DTMF payload type. The value must be 96~127.
AMR Payload Type	Sets AMR load type, range 96~127.
Headset Mic Gain	Sets the earphone's radio volume gain to fit different models of earphones.
Opus payload type	Sets Opus load type, range 96~127.
OPUS Sample Rate	Sets Opus sampling rate, including opus-nb (8KHz) and opus-wb (16KHz).
ILBC Payload Type	Sets the ILBC payload type. The value must be 96~127.
ILBC Payload Length	Sets the ILBC payload length
Enable MWI Tone	When there is a new voice message, the telephone will start a special dial tone.
Enable VAD	Determines whether voice activity detection is enabled.
Onhook Time	Configures a minimum response time. Default is 200ms.
EHS Type	EHS headset is available after enabling.
RTP Control Protocol (RTCP) Settings	
CNAME user	Sets CNAME user
CNAME host	Sets CNAME host
RTP Settings	
RTP keep alive	Holds the call and sends the packet after 30 seconds.
Alert Info Ring Settings	
Value	Sets the value to specify the ring type.

Parameters	Description
Ring Type	Type1-Type9

12.9 Telephone settings >> MCAST

This feature allows the user to make some kind of broadcast call to people who are in a multicast group. Users can configure a multicast DSS Key on the telephone, which allows users to send a Real Time Transport Protocol (RTP) stream to the pre-configured multicast address without involving SIP signaling. You can also configure the telephone to receive an RTP stream from a pre-configured multicast listening address without involving SIP signaling. You can specify up to 10 multicast listening addresses.

Table 24 - Multicast Parameters

Parameters	Description
Normal Call Priority	Defines the priority of the active call. 1 is the highest priority, 10 is the lowest.
Enable Page Priority	The voice call in progress takes precedence over all incoming paging calls.
Name	Server name of multicast being listened to.
Host: port	Server multicast IP address and port of the multicast being listened to.

12.10 Telephone settings >> Action

Action URL

Note: Action urls are used for IPPBX systems to submit telephone events. Please refer to manufacturer Action URL for details.

12.11 Telephone settings >> Time/Date

The user can configure the time settings of the telephone on this page.

Table 25 - Time&Date Settings

Parameters	Description
Network Time Server Settings	
Time Synchronized via SNTP	Enables time-sync through SNTP protocol.
Time Synchronized via DHCP	Enables time-sync through DHCP protocol.
Primary Time Server	Sets primary time server address.
Secondary Time Server	Sets secondary time server address when primary server is not reachable. The device will try to connect to secondary time server to get time synchronization.
Time Zone	Selects the time zone.
Resync Period	Time of re-synchronization with time server.

Parameters	Description
12-Hour Clock	Sets the time display in 12-hour mode.
Date Format	Selects the time/date display format.
Daylight Saving Time Settings	
Local	Chooses your local time zone. The telephone will set to Daylight Saving Time automatically based on the location.
DST Set Type	Chooses DST set type. If manual, you need to set the start time and end time.
Fixed Type	Daylight Saving Time rules are based on specific dates or relative rule dates for conversion. Displays in read-only mode in automatic mode.
Offset	The offset minutes when DST starts.
Month Start	The DST start month
Week Start	The DST start week
Weekday Start	The DST start weekday
Hour Start	The DST start hour
Minute Start	The DST start minute
Month End	The DST end month
Week End	The DST end week
Weekday End	The DST end weekday
Hour End	The DST end hour
Minute End	The DST end minute
Manual Time Settings	You can set your time manually.

12.12 Telephone settings >> Tone

This page allows users to configure a telephone prompt.

You can either select the country area or customize the area. If the area is selected, it will show the following information directly. If you choose to customize the area, you can modify the button tone, call back tone and other information.

Setting	Value
Select Your Tone:	United States
Dial Tone:	350+440/0
Ring Back Tone:	440+480/2000,0/4000
Busy Tone:	480+620/500,0/500
Congestion Tone:	
Call waiting Tone:	440/300,0/10000,440/300,0/10000,0/0
Holding Tone:	
Error Tone:	
Stutter Tone:	
Information Tone:	
Dial Recall Tone:	350+440/100,0/100,350+440/100,0/100
Message Tone:	
Howler Tone:	
Number Unobtainable Tone:	400/500,0/6000
Warning Tone:	1400/500,0/0
Record Tone:	440/500,0/5000
Auto Answer Tone:	

Figure 119 - Tone settings on the web

12.13 Telephone settings >> Advanced

The user can configure the advanced configuration settings in this page.

- Screen Configuration:
 - Backlight Active Level
 - Backlight Inactive Level
 - Contrast
 - Backlight Time
 - Screen Saver

- LCD Menu Password Settings:

The password is 123456 by default.

- Keyboard Lock Settings.
- Configure Greeting Words

The greeting message will display in the top left corner of the LCD when the device is idle, which is limited to 16 characters. The default characters are 'VOIP PHONE'.

12.14 Phonebook >> Contact

The user can add, delete, or edit contacts in the phonebook in this page. The user can browse the phonebook and sort by name, telephones, or filter by group.

To add a new contact, the user should enter the contact's information and press the "Add" button to add it. To edit a contact, click on the checkbox in front of the contact. The contact information will be copied to the contact edit boxes. Press the "Modify" button after you finish editing.

To delete one or multiple contacts, check the checkbox in front of the contacts you wish to delete and click the "Delete" button, or click the "Clear" button when selecting any contacts to clear the phonebook.

The user can also add multiple contacts to a group by selecting the group in the drop-down options in front of the "Add to Group" button at the bottom of the contact list, selecting contacts with a checkbox and clicking "Add to Group" to add selected contacts to the group.

Similarly, the user can select multiple users and add them to the blacklist by clicking the "Add to Blacklist" button.

12.15 Phonebook >> Cloud phonebook

Cloud phonebook

The user can configure up to 8 cloud phonebooks. Each cloud phonebook must be configured with an URL where an XML phonebook is stored. The URL may be based on the HTTP/HTTPS or FTP protocol with or without authentication. If authentication is required, the user must configure the username and password. To configure a cloud phonebook, the following information should be entered:

- Phonebook name (required)
- Phonebook URL (required)
- Access username (optional)
- Access password (optional)

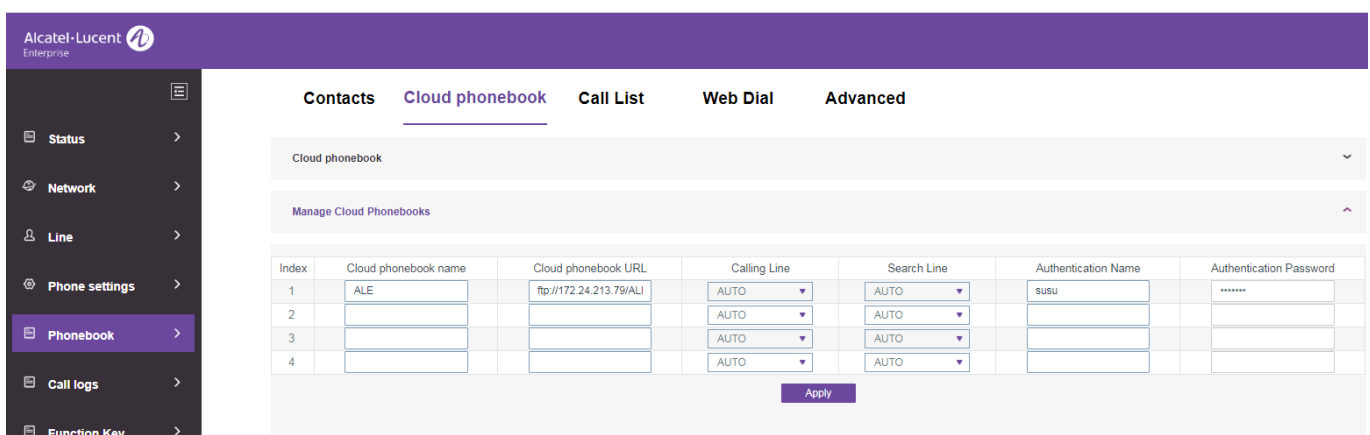

Index	Cloud phonebook name	Cloud phonebook URL	Calling Line	Search Line	Authentication Name	Authentication Password
1	ALE	ftp://172.24.213.79/ALI	AUTO	AUTO	susu	*****
2			AUTO	AUTO		
3			AUTO	AUTO		
4			AUTO	AUTO		

Figure 120 - Managing cloud phonebooks

LDAP settings

The cloud phonebook allows the user to retrieve a contact list from a LDAP Server through LDAP protocols. The user must configure the LDAP server information and search base to be able to use it on the device. If the LDAP server requests an authentication, the user should also provide a username and password.

To configure an LDAP phonebook, the following information should be entered,

- Display Title (required)
LDAP Server Address (required)
- LDAP Server Port (required)
Search Base (required)
- Access username (optional)
- Access password (optional)

Note: Refer to the LDAP technical documentation before creating the LDAP phonebook and phonebook server.

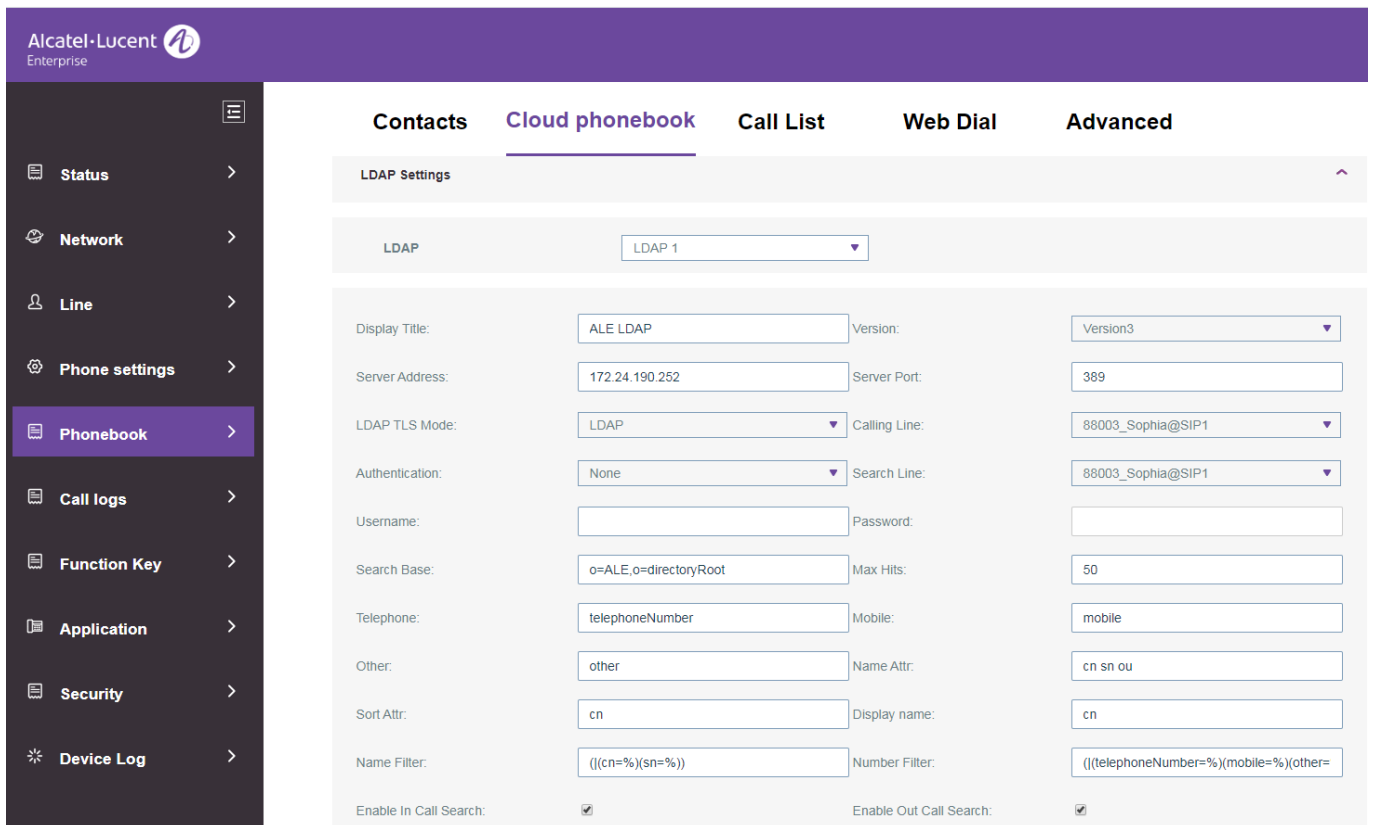

The screenshot displays the 'LDAP Settings' configuration page for 'LDAP 1'. The settings are as follows:

Field	Value	Field	Value
Display Title	ALE LDAP	Version	Version3
Server Address	172.24.190.252	Server Port	389
LDAP TLS Mode	LDAP	Calling Line	88003_Sophia@SIP1
Authentication	None	Search Line	88003_Sophia@SIP1
Username		Password	
Search Base	o=ALE,o=directoryRoot	Max Hits	50
Telephone	telephoneNumber	Mobile	mobile
Other	other	Name Attr	cn sn ou
Sort Attr	cn	Display name	cn
Name Filter	((cn=*)(sn=*))	Number Filter	((telephoneNumber=*)(mobile=*)(other=
Enable In Call Search	<input checked="" type="checkbox"/>	Enable Out Call Search	<input checked="" type="checkbox"/>

Figure 121 - LDAP setting

Web page preview

Telephone page supports preview of internet telephone directory and contacts

- After setting up the XML Voip directory or LDAP,
- Select [**Phonebook**] >> [**Cloud phonebook**] >> [**Cloud phonebook**] to select the type.
- Click XML/LDAP set to download the contacts for browsing.

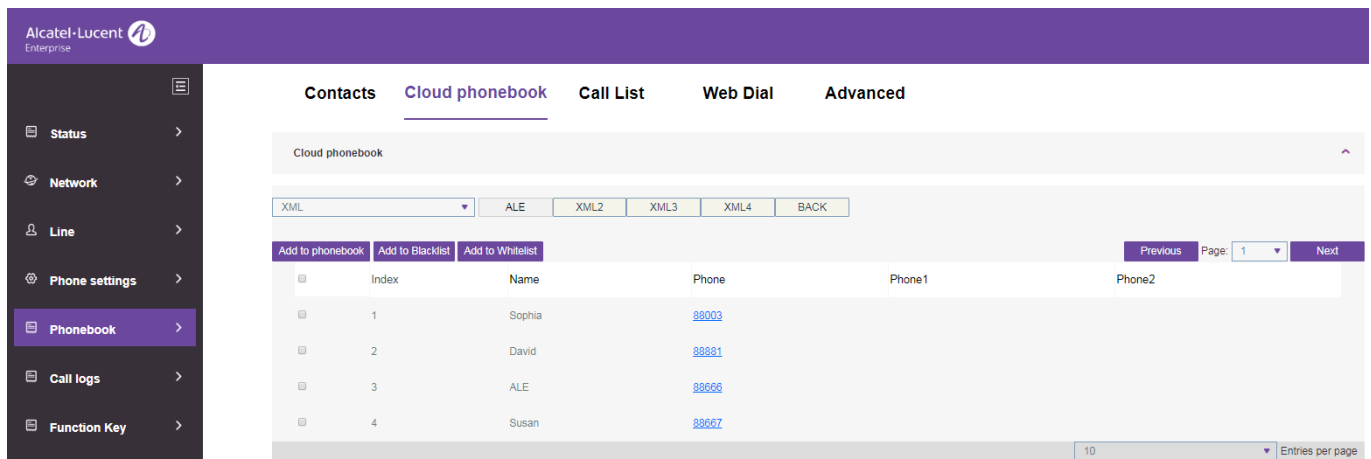

Figure 122 - Cloud phonebook browsing

12.16 Phonebook >> Call List

■ Restricted incoming calls:

This is similar to a blacklist. Add the number to the blacklist, and the user will no longer receive calls from the stored number until the user removes it from the blacklist.

Users can add specific numbers to the blacklist or add specific prefixes to the blacklist to block calls with all numbers with this prefix.

■ Allowed incoming calls:

When DND is enabled, the incoming call number can still call.

■ Restricted outgoing calls:

Adds numbers for restricted outgoing calls, and cannot be called until the number is removed from the table.

12.17 Phonebook >> Web Dial

Uses web pages for calling, replying, and hanging up operations.

12.18 Phonebook >> Advanced

Users can export the local phonebook in XML, CSV, and VCF format and save it on the local computer. Users can also import contacts into the phonebook in XML, CSV, and VCF formats.

Attention! If the user imports the same phonebook repeatedly, the same contact will be ignored. If the name is the same but the number is different, the contact is created again.

Users can delete groups or add new groups on this page. Deleting a contact group does not delete contacts in that group.

12.19 Call Log

The user can browse the complete call record on this page. The call record can be sorted by time. Call number, contact name or line, and the call record can be screened by call record type (incoming call, outgoing call, missed call, forwarded call).

The user can also save the number in the call record to his/her phonebook or add it to the blacklist/whitelist. Users can also dial the web page by clicking on the number in the Call Log.

Users can also download call records conditionally and save them locally.

12.20 Function Key >> Function Key

One-key transfer settings: establish new call, blind transfer, attended transfer, one-key three-party, Play DTMF.

One key transfer: For example, set the memory key to 4370. Press the memory key with 4374 when talking to decide whether to call 4370 or transfer 4374 to 4370.

Select memory key function: For example, set the telephone memory key value to 4370. When 4370 calls, press this key to hold the call or hang up.

The device provides 2 user-defined shortcuts that users can configure on a web page.

Table 26 - Function Key Configuration

Parameters	Description
Memory Key	<p>BLF (NEW CALL/BXFE/AXFER): This is used to prompt the user on the status of the subscribed extension, and it can also pick up the subscribed number, which helps the user monitor the status of the subscribed extension (idle, ringing, a call). There are 3 types of one-touch BLF transfer method. P.S. The user should enter the pick-up number for a specific BLF key to fulfill the pick- up operation.</p> <p>Presence: Compared to BLF, Presence is also able to view whether the user is online. Note: You cannot subscribe the same number for BLF and Presence at the same time.</p> <p>Speed Dial: You can call the number directly which you have set. This feature is convenient for dialing a number which you frequently dial.</p> <p>Intercom: This feature allows the operator or the secretary to connect the telephone quickly; it is widely used in office environments.</p>
Line	This can be configured as a Line Key. The user is able to make a call by pressing Line Key.
Key Event	The user can select a key event as a shortcut to trigger. For example: MWI/DND/Release/Headset/Hold/etc.
DTMF	This allows the user to dial or edit a dialed number easily.
URL	Opens the specific URL directly.
Multicast	Configures the multicast address and audio codec. The user presses the key to initiate the multicast.

Parameters	Description
Action URL	The user can use a specific URL to make basic calls to the telephone.
XML browser	Users can set the DSS Key for a specific URL download and other operations.

12.21 Function Key >> Softkey

The User Settings mode and displaying style and page.

Table 27 - Softkey Configuration

Parameter	Description
Softkey Mode	
Softkey mode	Disabled and More. Default is Disabled
Softkey Style	
Softkey display style	Softkey Exit on Left or Right
Screen	
Call Dialer	Redial/2aB/Delete/Exit/Call Back/Dial/Join/MWI/Local Contacts/Pickup/Call Log/Missed/Clear/In/Dialed/Pause/Next line/Prev line/Headset/Audio/Video/Remote XML/DSS Key
Conference	Hold/Split/End/Release/Mute/DSS Key/Headset
Desktop	Call Log/Menu/Local Contacts/DND/Prev Account/Next Account/Blacklist/Call Back/CallForward/Locked/Memo/Missed/MWI/Dialed/Reboot/Redial/Remote XML/Headset/Status/DSS Key/In
Divert Dialed	Redial/2aB/Delete/Exit/Forward/Local Contacts/Call Log/Clear/Missed/Dialed/Headset/Video/Audio/Remote XML/DSS Key
Ending	Redial/End/Headset/Release/DSS Key
Predictive Dialer	Dial/2aB/Delete/Exit/Call Back/Local Contacts/Redial/Pickup/MWI/Join/Call Log/Release/Missed/Pause/Dialed/Headset/Video/Audio/Remote XML/DSS Key/In/Next line/Prev line
Ringng	Answer/Forward/Reject/Mute/Release/Headset/Video/Audio/DSS key
Talking	Hold/Transfer/Conference/End/Mute/Release/New Call/Local Contacts/Listen/Call Log/Next call/Prev call/Private/Headset/Video/Audio/DSS Key
Transfer Alerting	End/Transfer/Headset/Release/DSS Key
Transfer Dialer	Redial/Delete/Exit/2aB/Dial/Local Contacts/Transfer/Call Log/Clear/Missed/Dialed/Pause/Headset/Video/Audio/Remote XML/DSS Key
Trying	End/Release/Headset/DSS Key
Waiting	Hold/Transfer/Conference/End/Answer/Forward/Mute/Next call/New call/Prev call/Reject/Release/Headset/Listen/Video/Audio/DSS Key

12.22 Function Key >> Advanced

■ Global Key Settings

Global Key Settings ^

Select MemoryKey Action: None Display Parked Info:

Apply

Figure 123 - Global key settings

■ Programmable key settings

Programmable Key Settings ^

Key	Desktop	Dialer	Calling	Desktop Long Pressed
Up	Call logs ▼	Prev Line(Pre ▼	None ▼	Status ▼
Down	None ▼	Next Line(Nex ▼	None ▼	None ▼
Left	None ▼	None ▼	None ▼	None ▼
Right	None ▼	None ▼	None ▼	None ▼
OK	Status ▼	None ▼	None ▼	Reset ▼

Apply

Figure 124 - Programmable key settings

Please refer to [Table 27 - Softkey configuration](#).

12.23 Application >> Manage Recording

See [9.3 Record](#) for details of recording.

12.24 Security >> Web Filter

The user can set up a configuration management telephone that allows only machines with a certain network segment IP access.

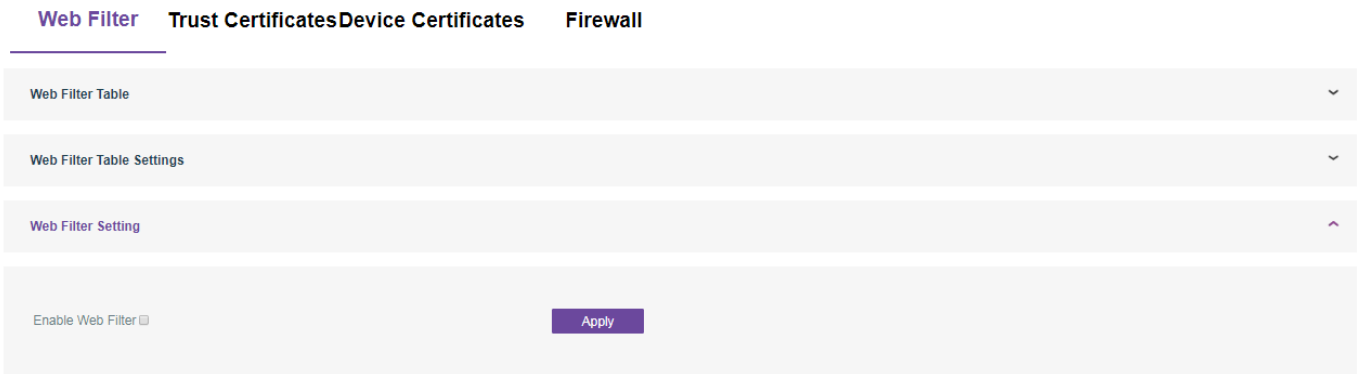

Figure 125 - Web filter settings

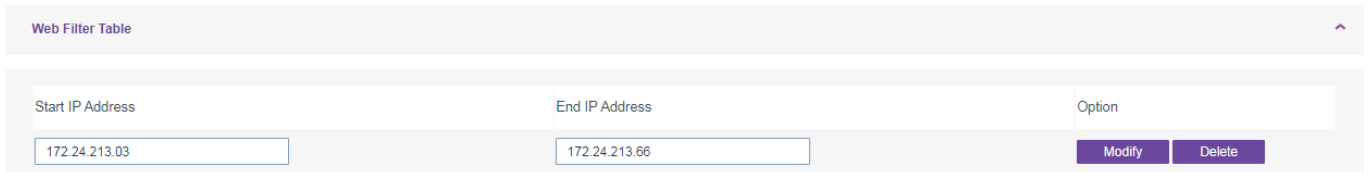

Figure 126 - Web Filter Table

IP segments can be added and removed. Configure the starting IP address within the start IP, end the IP address within the end IP, and click [**Add**] to submit to take effect. A large network segment can be set, or it can be divided into several network segments to be added. If the user wants to delete, select the initial IP of the network segment to be deleted from the drop-down menu, and then click [**Delete**] to apply.

To enable web page filtering, configure enable/disable web page access filtering. Click the “apply” button for this to take effect.

Note: If the device you are accessing is in the same network segment as the telephone, please do not configure the filter segment of the web page to be outside your own network segment; otherwise, you will not be able to log in to the web page.

12.25 Security >> Trust Certificates

To open a license certificate and general name validation, select the certificate module. You can upload and delete uploaded certificates.

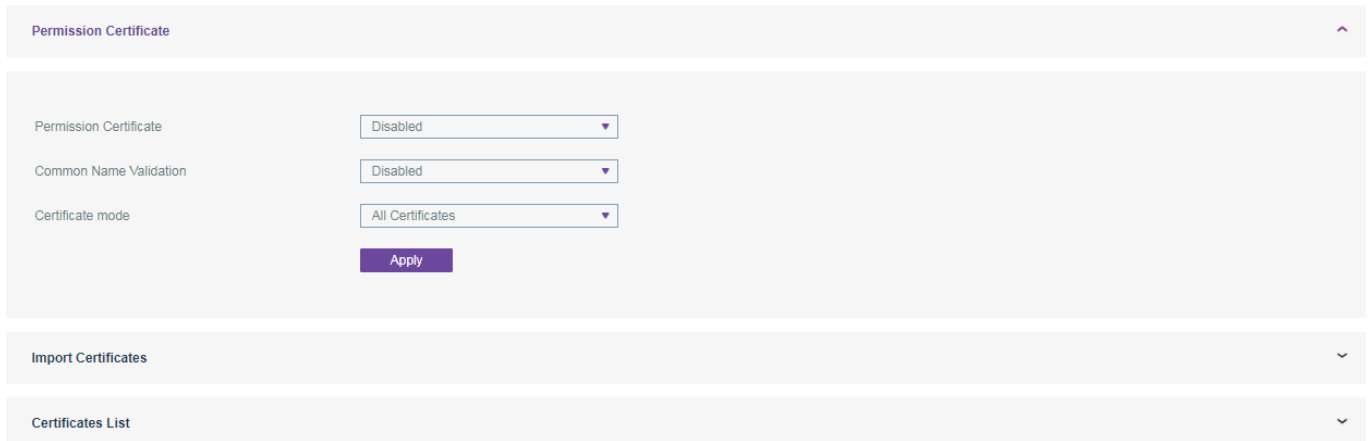

Permission Certificate

Permission Certificate

Common Name Validation

Certificate mode

Apply

Import Certificates

Certificates List

Figure 127 - Certificate of settings

12.26 Security >> Device Certificates

Select the device certificate as the default and custom certificate. You can upload and delete uploaded certificates.

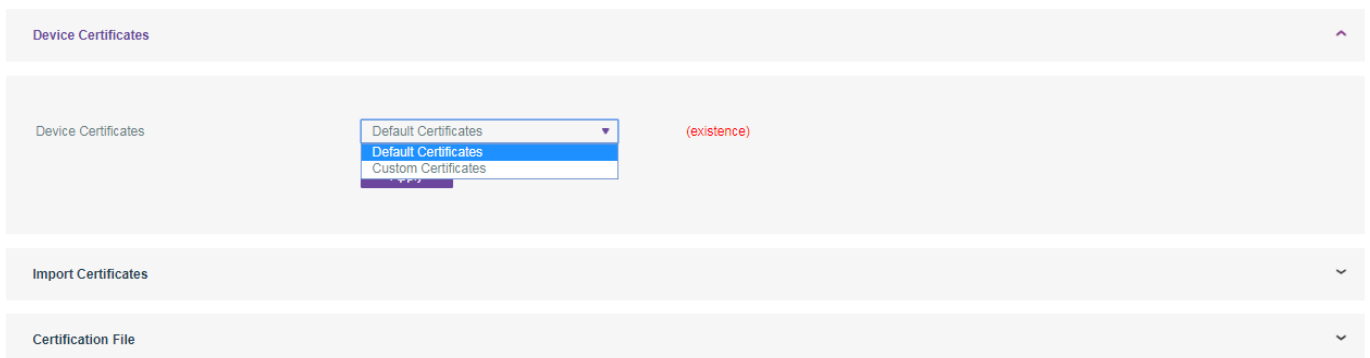

Device Certificates

Device Certificates (existence)

Import Certificates

Certification File

Figure 128 - Device certificate setting

12.27 Security >> Firewall

Figure 129 - Network firewall settings

The user can set whether to enable input through this page, output firewall and set the firewall input and output rules. Using these settings can prevent malicious network access or restrict internal users' access to certain resources of the external network, which can improve security.

A simple firewall module is used for setting firewall rules. This feature supports two types of rules: input rules and output rules. Each rule is assigned an ordinal number, allowing up to 10 for each rule.

Considering the complexity of firewall settings, the following is an example for illustration.

Table 28 - Network Firewall

Parameter	Description
Enable Input Rules	Indicates that the input rule application is enabled.
Enable Output Rules	Indicates that the output rule application is enabled.
Input/Output	To select whether the currently added rule is an input or output rule.
Deny/Permit	To select whether the current rule configuration is disabled or allowed;
Protocol	There are four types of filtering protocols: TCP UDP ICMP IP.
Src Port Range	Filter port range
Src Address	Source address can be a host address, network address, or all addresses 0.0.0.0; It can also be a network address similar to *.*.*.0, such as: 192.168.1.0.
Dst Address	The destination address can be either the specific IP address or the full address 0.0.0.0; It can also be a network address similar to *.*.*.0, such as: 192.168.1.0.
Src Mask	This is the source address mask. When configured as 255.255.255.255, it means that the host is specific. When set as 255.255.255.0, it means that a network segment is filtered.

Parameter	Description
Dst Mask	This is the destination address mask. When configured as 255.255.255.255, it means the specific host. When set as 255.255.255.0, it means that a network segment is filtered.

After setting, click **[Add]** and a new item will be added in the firewall input rule, as shown in the figure below:

Firewall Input Rule Table								
Index	Deny/Permit	Protocol	Src Address	Src Mask	Src Port Range	Dst Address	Dst Mask	Dst Port Range
1	deny	udp	192.168.1.14	255.255.255.0	5060-5061	192.168.1.18	255.255.255.0	5060-5061

Figure 130 - Firewall input rule table

Then select and click the **[Apply]** button.

In this way, when the device is running, if 192.168.1.118 is the ping, the packet cannot be sent to 192.168.1.118 because the output rule forbids it. However, the other IP of the ping 192.168.1.0 network segment can still normally receive the response packet from the destination host.

Rule Delete Option			
Input/Output	<input type="text" value="Input"/>	Index To Be Deleted	<input type="text"/>
			<input type="button" value="Delete"/>

Figure 131 - Delete firewall rules

Select the list you want to delete and click **[Delete]** to delete the selected list.

12.28 Device Log >> Device Log

You can get the device log, and when you encounter an abnormal problem, you can send the log to the technician to locate the problem. See [13.6 Getting log information](#).

13 Troubleshooting

When the telephone is not functioning normally, the user can try the following methods to restore normal operation of the telephone or collect relevant information and send a problem report to the manufacturer's technical support mailbox.

13.1 Get device system information

Users can get information by pressing the **[Setting]** >> **[Network]** and **[Version]** option in the telephone. The following information will be provided:

The network information

Equipment information (model, software and hardware version), etc.

13.2 Reboot device

Users can reboot the device from the soft-menu by going to **[Setting]** >> **[Reboot]** and confirm the action with **[OK]**. Or, simply remove the power supply and restore it again.

13.3 Reset device to factory default

Resetting Device to Factory Default will erase all the user's configurations, preferences, databases and profiles on the device and restore the device back to the state of factory default.

To perform a factory default reset, the user should press **[Setting]** >> **[Admin]**, and then input the password to enter the interface. Then choose **[Restore factory]** and press **[OK]**. Choose the items to be cleared and confirm the action by **[OK]**. The device will be rebooted to a clean factory default state.

13.4 Screenshot

If there is a problem with the telephone, the screenshot can help the technician locate the function and identify the problem. In order to obtain screen shots, log in to the telephone web page **[Status]** >> **[Tools]**, and you can capture the pictures of the main screen and the secondary screen (you can capture them in the interface with problems).

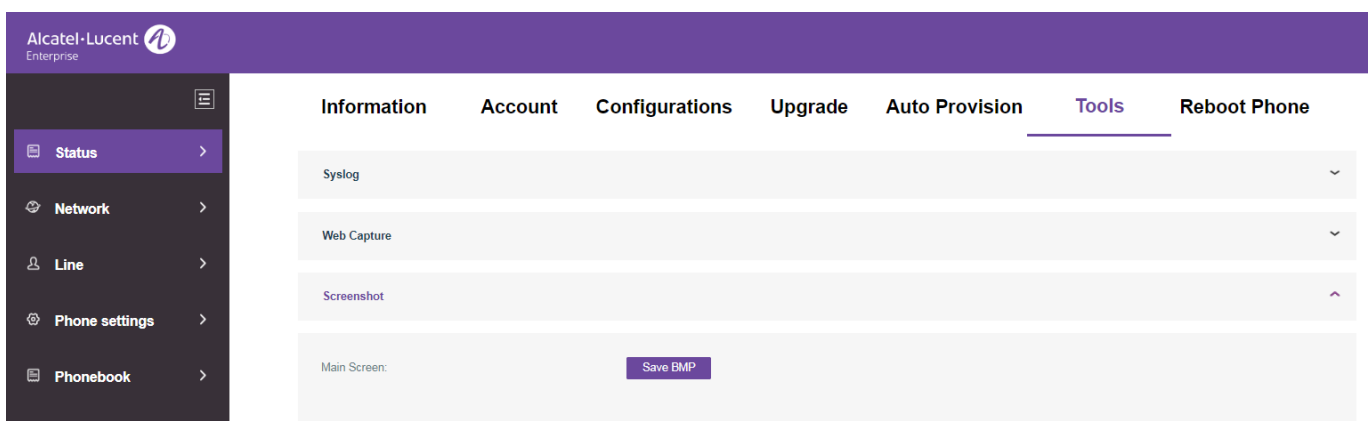

Figure 132 - Screenshot

13.5 Network packets capture

Sometimes it is helpful to dump the network packets of the device for issue identification. To get the device packets dump, log in to the device web portal, open the page **[Status]** >> **[Tools]** and click **[Start]** in “Network Packets Capture” section. A pop-up message will prompt the user to save the capture file. The user then performs the relevant operations such as activating/deactivating a line or making telephone calls and clicks the **[Stop]** button in the web page when the operation is finished. The device network packets have been dumped to the saved file during this period.

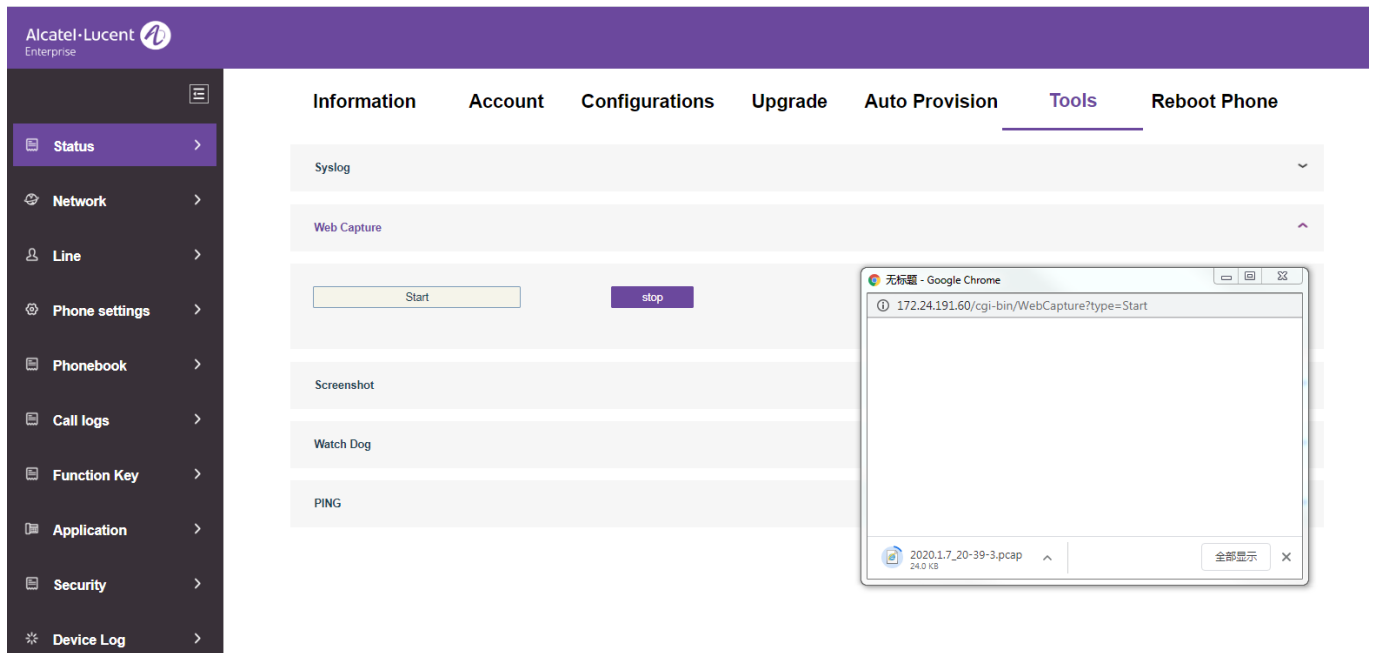

Figure 133 - Web capture





The user may examine the packets with a packet analyzer or send them to the manufacturer’s support mailbox.

13.6 Getting log information

Log information is helpful when encountering an exception problem. In order to get the telephone’s log information, log in to the telephone web page, open the page **[Device log]**, click the **[Start]** button, follow the steps of the problem until the problem appears, and then click the **[End]** button, and **[Save]** to local analysis or send the log to the technician to locate the problem.

13.7 Common problems

Table 29 - Problems

Trouble Case	Solution
Device could not boot up	<ol style="list-style-type: none"> 1. The device is powered by external power supply via a power adapter or PoE switch. Please use the standard power adapter provided by the manufacturer or a PoE switch that meets the specifications, and check whether device is well connected to the power source. 2. If you saw "POST MODE" on the device screen, the device system image has been damaged. Please contact your location's technical support to help you restore the telephone system.
Device could not register to a service provider	<ol style="list-style-type: none"> 1. Please check whether the device is well connected to the network. The network Ethernet cable should be connected to the  [Network] port NOT the  [PC] port. If the cable is not well connected to the network, this icon  [WAN disconnected] will be flashing in the middle of the screen. 2. Please check whether the device has an IP address. Check the system information. If the IP displays "Negotiating...", the device does not have an IP address. Please check whether the network configuration is correct. 3. If the network connection is fine, please check your line configurations again. If all configurations are correct, please contact your service provider to get support, or follow the instructions in "13.5 Network packets capture" to get the network packet capture of the registration process and send it to the manufacturer's support to have the manufacturer analyze the issue.
No Audio or Poor Audio in Handset	<ol style="list-style-type: none"> 1. Please check whether the handset is connected to the correct handset  port, NOT the headphone  port. 2. The network bandwidth and delay may be not suitable for an audio call at the moment.
Poor Audio or Low Volume in Headphone	<ol style="list-style-type: none"> 1. There are two headphone wire sequences on the market. Please use the headphone provided by the manufacturer, or consult the manufacturer's the wire sequence if you wish to use a third-party headphone. 2. The network bandwidth and delay may be not suitable for an audio call at the moment.
Audio is distorted at the far- end in hands-free speaker mode	<p>This is usually due to loud volume feedback from speaker to microphone. Please lower the speaker volume a little bit, and the distortion will be gone.</p>

The Alcatel-Lucent name and logo are trademarks of Nokia used under license by ALE. To view other trademarks used by affiliated companies of ALE Holding, visit: www.al-enterprise.com/en/legal/trademarks-copyright. All other trademarks are the property of their respective owners. The information presented is subject to change without notice. Neither ALE Holding nor any of its affiliates assumes any responsibility for inaccuracies contained herein. © 2020 ALE International. All rights reserved. www.al-enterprise.com.